

Movement by Perfection



The Royal League in **ventilation**, control and drive technology



FANselect

User's Manual

FANselect

User's Manual (valid as of Version 1.01 Edition June 2013)

1. Start FANselect.....	3	9. Web update	18
1.1. Registration	3	10. General notes	19
1.2. Login	3	10.1. Notes on product portfolio and performance data	19
2. Screen layout FANselect.....	4	10.2. ErP Directive	19
3. Fan selection	5	10.3. Notes on TUEV certification of the program	20
3.1. Step by step	5	10.4. General.....	20
3.2. Selection of type	7	10.5. Copyright	20
3.3. Additional selection criteria.....	7	10.6. Liability for legal and material defects / other liability	21
3.4. Entry of duty point	7	10.7. Privacy	21
3.5. Entry of installation losses	8	11. Technical notes.....	22
3.6. Search for article number or type key	8	11.1. Explanation of technical details	22
4. Comparison of fans	9	11.2. Aerodynamics and acoustics	23
5. Additional functions	9	11.3. Noise level data.....	24
5.1. Display of SFP classes (Specific Fan Power).....	9	11.4. Electrical connection and motor.....	26
5.2. Product description.....	10	11.5. Installation and usage information	27
5.3. Saving watch list and LCC data	10	12. Explanation of terms	33
5.4. Saving options.....	10	12.1. Formula symbols and units	33
5.5. Saving selection criteria.....	11	12.2. Type key	35
5.6. Selection of system components.....	12	12.3. Definition of performances and efficiencies	38
6. Watch list.....	13	12.4. Definition of the main dimensions	39
6.1. Function.....	13	14. Documentation of the FANselect.dll	40
6.2. Saving and loading the watch list.....	13	14.1. General.....	40
7. Life-Cycle-Costs (LCC)	14	14.2. DLL functions	41
7.1. Function.....	14	14.3. Requests to the FANselect.dll.....	42
7.2. Saving the LCC load profile.....	15	14.4. Summary request parameters.....	51
7.3. Saving the LCC comparison	15	14.5. Summary output parameters	53
8. Output of the selection of fans	16	15. Document history	57
8.1. Function.....	16	16. ZIEHL-ABEGG global	59
8.2. Output PDF	17		
8.3. Output RTF	17		
8.4. Output CSV	17		
8.5. Direct request (send to ZIEHL-ABEGG SE).....	17		
8.6. Send to...	17		



1. Start FANselect

1.1. Registration

To use FANselect you have to apply for first time registration under www.FANselect.info. After registration you will receive an e-mail with your personal login.

Please keep your personal login carefully because you need it every time you start FANselect.

1.2. Login

With your assigned login data you can log in to the ZIEHL-ABEGG SE FANselect application. Type in your user name and password and accept the terms of use.

To save the login data, you can use the "AutoComplete" function of your browser or make the data available for FANselect-WEB and FANselect-portable by a cookie.

Save with the auto "complete" function in the Internet Explorer (fig. 1): Extras -> Internet options -> Tabs -> Contents -> Settings

At the next login you will be asked whether you want to save the data. Confirm with "YES".

Save the login data with the cookie of the FANselect function (fig. 2): Enter login data -> activate "Save login" -> confirm general terms of use -> OK

Confirm the next message with OK. Your data are inserted automatically the next time you open FANselect (as long as the cookies are not deleted). The cookies can be deleted as required with the browser function or the appropriate FANselect option.

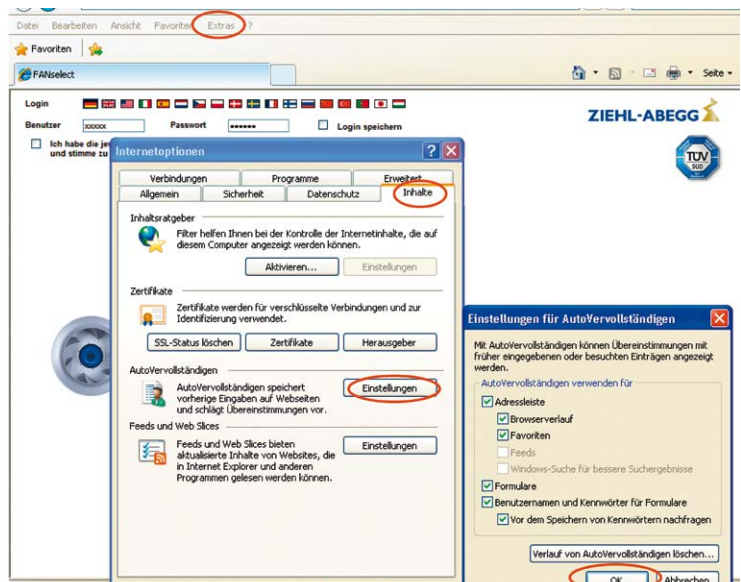

Figure 1: Settings for filling in login data automatically



Figure 2: Saving login data with cookie

2. Screen Layout FANselect



Options menus including the watch list

watch list options help logout

Tab navigation

product range
fan selection
details
system components
output

FANselect

product range

all

- Premium Efficiency | EC fans
- FE2owlet-ECblue with ZApplus
- FE2owlet-ECblue
- Vpro-ECblue
- Cpro-ECblue
- C-ECblue
- Premium Quality | AC fans
- FE2owlet with ZApplus
- FE2owlet
- MAXvent owlet



goto selection fan

fan designs

all

- axial fans
- FE2owlet-ECblue with ZApplus
- FE2owlet-ECblue
- FE2owlet with ZApplus
- FE2owlet
- MAXvent owlet
- centrifugal fans
- Vpro-ECblue
- Vpro
- Coro-ECblue

reset

EC-Fans

Ziehl-Abegg Premium Efficiency Fans display highest quality with maximum efficiency. Additionally the ECblue fans satisfy with simple use.



Axial Fans & Centrifugal Fans

Axial and centrifugal fans from Ziehl-Abegg.

back next

Navigation button

Figure 3: Screen layout FANselect

3. Fan Selection

3.1. Step by Step

The following points only give you a brief overview of the individual steps for selecting fans with FANselect. A more detailed explanation of the individual functions is given in the following subsections.

1. Selection of the product range on the logon page by clicking on the picture of the product in the middle. Advanced selection of products is located in the "product range" tab.
2. Confirmation of the selected types by clicking on the "go to fan selection" or "next" button. Multiple selections are possible.



Figure 4: Product range

3. Selection of the duty point in the "fan selection" tab.
4. Confirmation of selection by clicking on the "search" button. Filtering of the search results by filling in "additional selection criteria" and clicking on the "search" button. The best values are marked dark blue in the hitlist. The table is sorted in ascending or descending order by clicking on the respective column header. The terms of the respective column are explained in a "tooltip". If installation dimensions were entered under "installation losses" in the "additional selection criteria", the installation ratio is shown as an "installation ratio" column in the result list.
5. Selection of a product by marking the corresponding line of the hitlist. The line is highlighted grey, confirmation by a double click or "next". (Fans highlighted with a "*" after the article number are calculated motor-technically according to VDI 6014.)

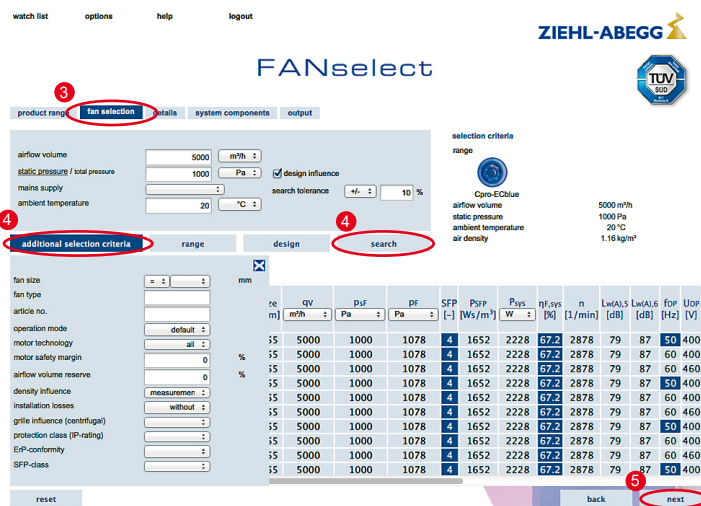

Figure 5: Hitlist

Relevant information and the characteristic fields for the product in the “details” tab. Chart fields can be enlarged by clicking on the zoom icon or the diagram. The duty point can be changed by clicking in the air performance chart. Other curves can be shown (by clicking on the values table) in the magnified display of the “power consumption”, “efficiency” and “acoustics” curves. For example, the curves for LW5, LW(A)5, LW6, LW(A)6 can be displayed in the acoustics chart.

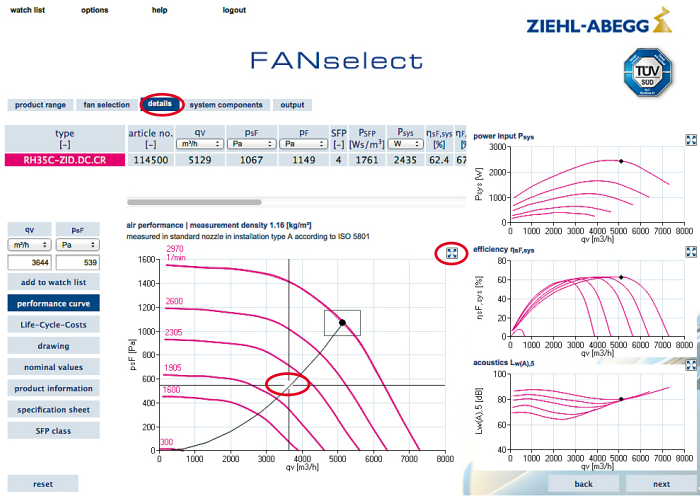

Figure 6: Details

Selection of system components. Open the desired system components and accept by specifying the quantity.



Figure 7: System components

Output as a pdf, rtf or csv file in the “output” tab. The output can be mailed directly to the info address of the respective subsidiary with the “direct inquiry” option. See chapter 8.5.

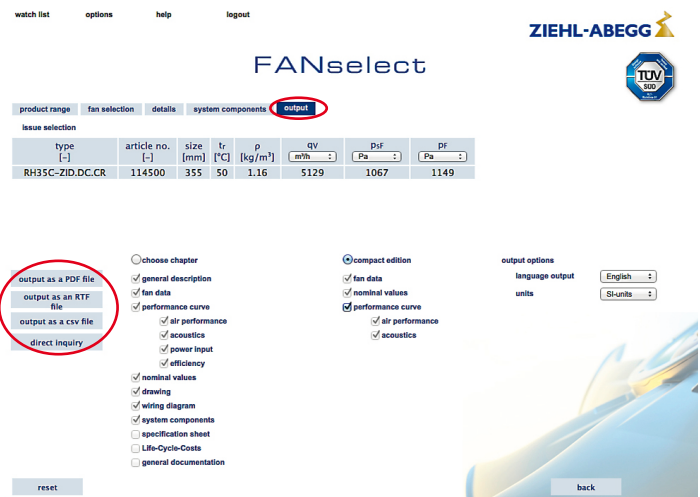

Figure 8: Output

3.2. Selection of Type

Advanced selection of products is located in the “product range” tab. Multiple selection is possible with the ‘ctrl’ key of the keyboard pressed within a group.

3.3. Additional Selection Criteria

The search result be limited in “additional selection criteria” in the “fan selection” tab.

3.4. Entry of Duty Point

To select a fan, an airflow and a static pressure or total pressure must be entered with the desired unit. The units can be selected in the corresponding dropdown bars.

The units system can be changed generally from SI to Imperial units. **“options” > “units system”**.

FANselect offers the possibility of entering a static pressure difference as well as a total pressure difference. Change the option by clicking on the **“static pressure/total pressure”** item.

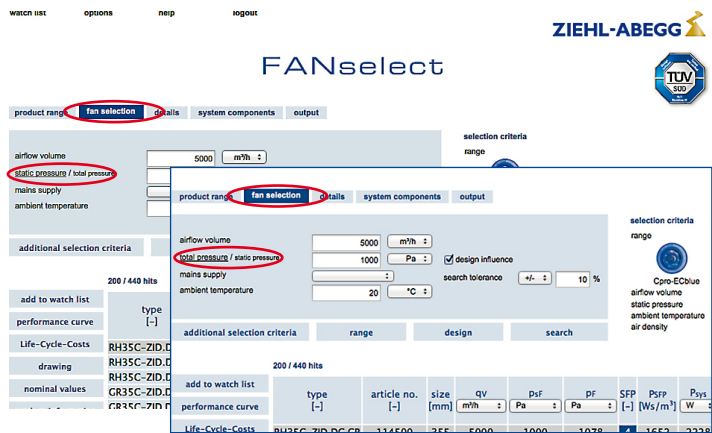

Figure 9: Selection of static pressure or total pressure

3.5. Entry of Installation Losses

The influence of installation losses in air handling units can be considered as follows:

Menu "additional selection criteria"

Set option "installation losses" on "with".

Enter the height, width and depth of the air handling unit. The recommended distance between the housing walls and the centrifugal fan is 1.8 x D. If the value drops below this, the ratio values are marked in colour in the result list.

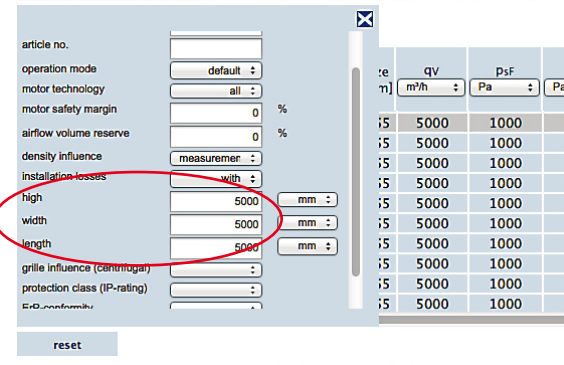

Figure 10: Installation losses

Attention! The installation losses will only be considered in the calculations with the Cpro, C and Vpro types!

3.6. Search for Article Number or Type Key

To search for a specific article number or type, enter the article number or a specific fan type key designation in the appropriate fields in the "additional selection criteria".

Note that in this procedure the entered duty point is not considered and all fans are displayed which correspond to the entered article number or type key. If the duty point is in the characteristic field of the fan, the data are still calculated and output, otherwise the fans are listed without a corresponding calculation.

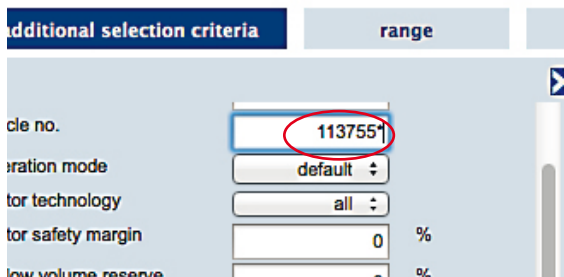

Figure 11: Article number search

Two characters can be used as wild cards. The "?" serves as a wild card for one character and the "*" as a wild card for an indefinite number of characters. When a "?" is used, a "*" should follow as the last character to increase the number of hits.



Figure 12: Fan type search

4. Comparison of fans

FANselect can compare up to three fans according to air performance and operating costs. To be able to compare fans, the relevant fans have to be added to the “watch list”.

Selection of a product by marking the corresponding line of the hitlist. Confirmation with the button “add to watch list” The product is added to the watch list. The fan can also be saved to the watch list from the “Details” tab. The number of fans in the watch list is displayed in brackets after the watch list and increases accordingly when a fan is added to the watch list.

In the watch list, up to three products can be chosen for comparison. Selection through activation of checkboxes in column "compare". The colour code assignment will be maintained in all further steps.

Start comparison with “compare” button in the column header. The watch list is closed and comparison according to air performance is displayed in the “details” tab.

5. Additional Functions

5.1. Display of SFP Classes (Specific Fan Power)

The European standard DIN-EN 13779 prescribes different classifications of fans. These efficiency classes are calculated by FANselect and output in the result list, the Details tab and the printouts. They can also be displayed directly in the air performance chart field in FANselect. To do this, click on the “SFP classes” button on the left of the air performance capacity curve. In the legend in the upper right corner of the air performance chart the SFP class is marked by a “*” where the chosen duty point is valid.

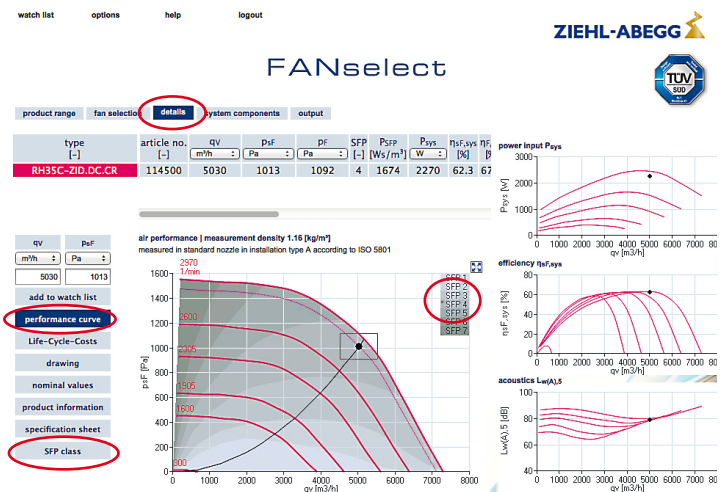

Figure 13: SFP classes

5.2. Product Description

Product descriptions can be opened with the “product information” button in the “fan selection” tab. Selection of a product by marking the corresponding line of the hitlist and calling the information with the “product information” button.

add to watch list	type
performance curve	[-]
Life-Cycle-Costs	RH35C-ZID.DC.CF
drawing	RH35C-ZID.DC.CF
nominal values	GR35C-ZID.DC.CF
product information	GR35C-ZID.DC.CF
	GR35C-ZID.DC.CF

Figure 14: Product information

5.3. Saving Watch List and LCC Data

Both FANselect-WEB and FANselect-portable offer the possibility of saving different settings and data.

Attention! Saved data are deleted from the server if they are not recalled for more than 12 months!

Please use the appropriate options at the bottom

of the respective pages to save the watch list, the load profile of the LCC calculation and the fan data of the LCC calculation. See chapter 6.2.

5.4. Saving Options

Proceed as follows to save the global settings (language, units system):
 Select the desired settings.
 Menu “options” > “settings” and save the selected options with the “save options” item.

The following are saved:

- the selected language setting
- the selected units system
- the entered data of the contact form.

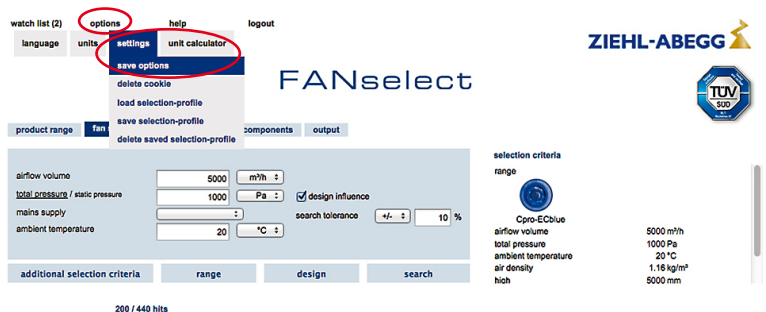

Figure 15: Saving options

5.5. Saving Selection Criteria

Proceed as follows to save repeatedly used selection criteria:

Set all selection criteria as desired.

Select "options" > "settings" > "save selection profile".

The saved selection criteria are loaded on the "fan selection" page at the next login and a search can be started immediately.

The following are saved:

- all selection criteria of the "fan selection" page
- the selected options on the "output" page.

The most recently saved selection criteria can be reloaded with the "options" > "settings" > "load selection profile" option.

All saved selection criteria and options are reset to the factory settings with "options" > "settings" > "delete selection profile".

Attention! The saved options of the "save options" menu remain unaffected by this.

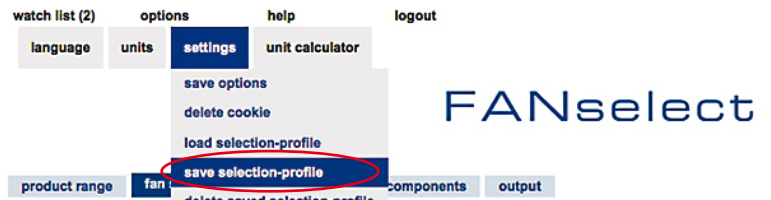



Figure 16 "Save selection criteria" option

5.6. Selection of System Components

System components can be selected in the "System components" tab.

1. Entry of the amount wanted in appropriate fields
2. A description of the individual system components can be opened by clicking on the product name.
3. Overview of selected items
4. Confirmation of selection with the "next" button

watch list (2) options help logout

ZIEHL-ABEGG 

FANselect





product range fan selection details **system components** output

type [-]	article no. [-]	size [mm]	mains supply [-]	UN [V]	PN [kW]
RH35C-ZID.DC.CR	114500	355	3~ 400V 50Hz	400	2.50

3 selected system components

system components	article no.	quantity
Inlet ring RH..C, with measuring device	00401296	1

configure system components **quantity**

RH35C-ZID.DC.CR 114500		<input style="width: 40px;" type="text" value="1"/>
inlet nozzle 		
not available	<u>inlet ring RH..C, with measuring device</u> -type galvanised -article no.: 00401296	<input style="width: 40px;" type="text" value="1"/>
not available	2 <u>guard grille</u> -type guard grille -article no.: 00409761	<input style="width: 40px;" type="text" value="0"/>
not available	<u>inlet ring RH..C, with measuring device</u> -type powder coated -article no.: 00401740	<input style="width: 40px;" type="text" value="0"/>
not available	<u>guard grille</u> -type guard grille -article no.: 00409761	<input style="width: 40px;" type="text" value="0"/>
control component 		

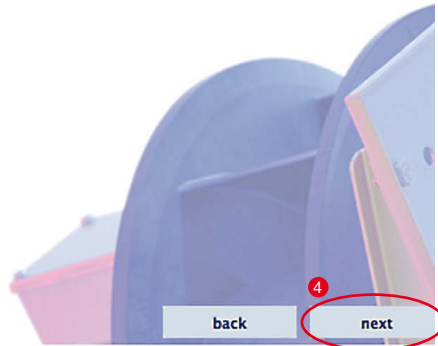

 4

Figure 17: Selection of system components

6. Watch List

6.1. Function

A central element of FANselect is the "watch list". Here selected fans can be deposited, saved, compared or output with a multiple selection. Selection of a product by marking the corresponding line of the hitlist. Confirmation with the button "add to watch list" The fan is then added to the watch list. This can also be done with the fan shown in the "details" tab.

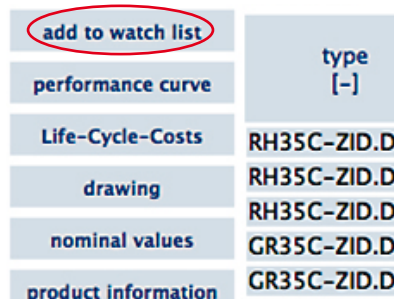

Figure 18 "Add to watch list"

The watch list can be reached with the "watch list" item in the options bar. The watch list is closed with the "close" button, the "X" symbol on the right or reselection of the "watch list" item in the options bar.

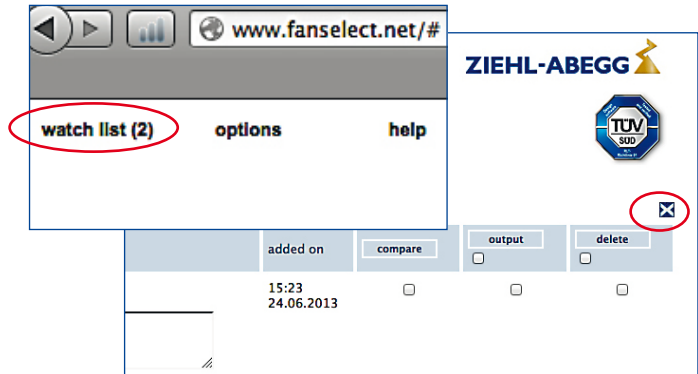

Figure 19: Accessing and closing the watch list

6.2. Saving and Loading the Watch List

Proceed as follows to save the watch list:

1. Open the "save as..." dialog box with the "Save as..." button.
2. Enter the save name. The saved names are displayed in the respective drop-down bar and can be loaded at any time.
3. Proceed as follows to load the watch list:
4. Select the watch list saved in the drop-down bar and press the "load" button to load the desired list. FANselect-WEB saves the watch lists as described on a ZIEHL-ABEGG server. With FANselect-portable the user can select the local memory location himself with the usual MS-Windows options.

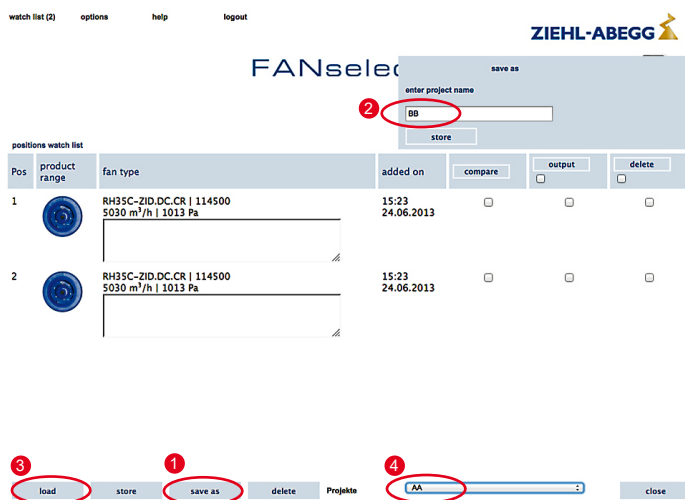

Figure 20: "save as" watch list

7. Life-Cycle-Costs (LCC)

7.1. Function

Probable operating costs can be determined with FANselect in a subsequent comparison which is selected by the watch list.

1. Open the input dialog with the "edit" button.
2. Select desired criteria:
 - type of control
 - amount and costs of fans and controllers
 - installation costs
3. Confirmation of the entered values with the "OK" button. The entries determine the investment and operating costs over the time in operation.
4. Every time the parameters (load profile, fan control) are changed, the curve must be recalculated with the "refresh" button.
5. Each line of the load profile corresponds to a fan load in percent of the speed or air flow rate at a certain number of hours in the year.

watch list (3) options help logout

ZIEHL-ABEGG 

FANselect



product range fan selection **details** system components output

type [-]	n _{max} [%]	qV [m ³ /h]	psF [Pa]	control [-]	energy/year [€]	invest [€]		
RH35C-ZID.DC.CR	97	5164	1067	EC	280	520	Edit	delete
external type/non ZA type		5000	1000		0		Edit	delete

qV PsF

m³/h Pa

5000 1000

add to watch list

performance curve

Life-Cycle-Costs

drawing

nominal values

product information

specification sheet

reset

operating costs

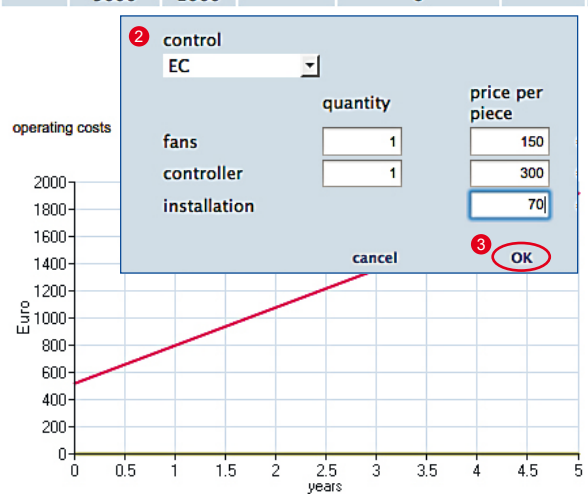

control: EC

quantity: fans 1, controller 1, installation 1

price per piece: fans 150, controller 300, installation 70

cancel **OK**

load profile

hours at	% of n duty
1000	100 %
1000	50 %
1000	25 %

LCC lines

LCC columns

5760 hours remaining time

energy costs: 0.10 €/kWh

price rise: 00 %

load profile: [dropdown]

load store

save as delete

back next

refresh

Figure 21: LCC

7.2. Saving the LCC Load Profile

It is saved as described in chapter 6.2. Proceed as follows to save the LCC load profile:

Open the "save as..." dialog box with the "save as..." button.

Enter the save name. The saved names are displayed in the respective dropdown bar and can be loaded at any time.

Proceed as follows to load the LCC load profile:

Select the LCC comparison saved in the dropdown bar and press the "load" button to load the desired comparison.

Figure 22: Load profile

Figure 23: "save as"

8. Output of the Selection of Fans

8.1. Function

In the "Output" tab the selection of products is exported to different file formats. The list presented there shows the fans which are transferred to the output. Comments can be edited in the free text field in the "watch list". A "compact edition" with the most important product information on two

pages or a detailed edition can be selected. The contents of the detailed edition are determined with the respective checkboxes under the "choose chapter" option. The option must be activated to select individual content blocks.

General fan description	Output of the product description
Fan data	Output of type data
Performance curve	Output of performance curves
acoustics	Output of performance curves
air handling capacity	Output of performance curves
power consumption	Output of performance curves
efficiency	Output of performance curves
Nominal data	Output of nominal data
Drawing	Output of drawing graphic
Wiring diagram	Output of wiring diagram graphic
System components	Output of system components
Specification sheet	Output of specification sheet, if available
Life-Cycle-Costs	Output of operating costs calculation
General documentation	Output of general documentation (e. g. laboratory conditions), if available

watch list (3) options help logout



FANselect

product range	fan selection	details	system components	output
---------------	---------------	---------	-------------------	---------------

Issue selection								
type [-]	article no. [-]	size [mm]	tr [°C]	ρ [kg/m³]	QV [m³/h]	PsF [Pa]	PF [Pa]	
RH35C-ZID.DC.CR	114500	355	50	1.16	5000	1000	1078	

output as a PDF file

output as an RTF file

output as a csv file

direct inquiry

reset

choose chapter

- general description
- fan data
- performance curve
 - air performance
 - acoustics
 - power input
 - efficiency
- nominal values
- drawing
- wiring diagram
- system components
- specification sheet
- Life-Cycle-Costs
- general documentation

compact edition

- fan data
- nominal values
- performance curve
 - air performance
 - acoustics

output options

language output: English ▾

units: SI-units ▾

back

Figure 24: Output

8.2. Output PDF

With this option the selected contents are exported in a PDF document and can be opened with Acrobat Reader.

8.3. Output RTF

With this option the selected contents are exported in a document in RTF format and can be opened with MS Word for example.

8.4. Output CSV

With this option the selected contents are exported in a document in CSV format and can be opened with MS Excel for example.

8.5. Direct inquiry... (send to ZIEHL-ABEGG SE)

With this option the selected contents are exported in a PDF document, a new mail of the mailing program (e.g. Outlook) is opened and added as an annex to this mail. The form data entered are inserted into the mail and the e-mail address of the responsible contact person at ZIEHL-ABEGG is entered into the address line.

In FANselect-WEB a link to the document is inserted in place of the PDF file.

8.6. Send to... (only with FANselect-portable)

With this option the selected contents are exported in a PDF document, a new mail of the mail client (e.g. Outlook) is opened and added as an annex to this mail.

9. Web Update (only with FANselect-portable)

The Web update is carried out in the options bar of the "options" menu with the entry "Web-Update". The update routine is started, required data are downloaded from the ZIEHL-ABEGG server and are available the next time FANselect is started. FANselect is restarted after successful Web update.

Attention! An Internet connection is required during the entire update process!
The update can last a very long time. The update continues even though the program is not seen to be responding for a long time.

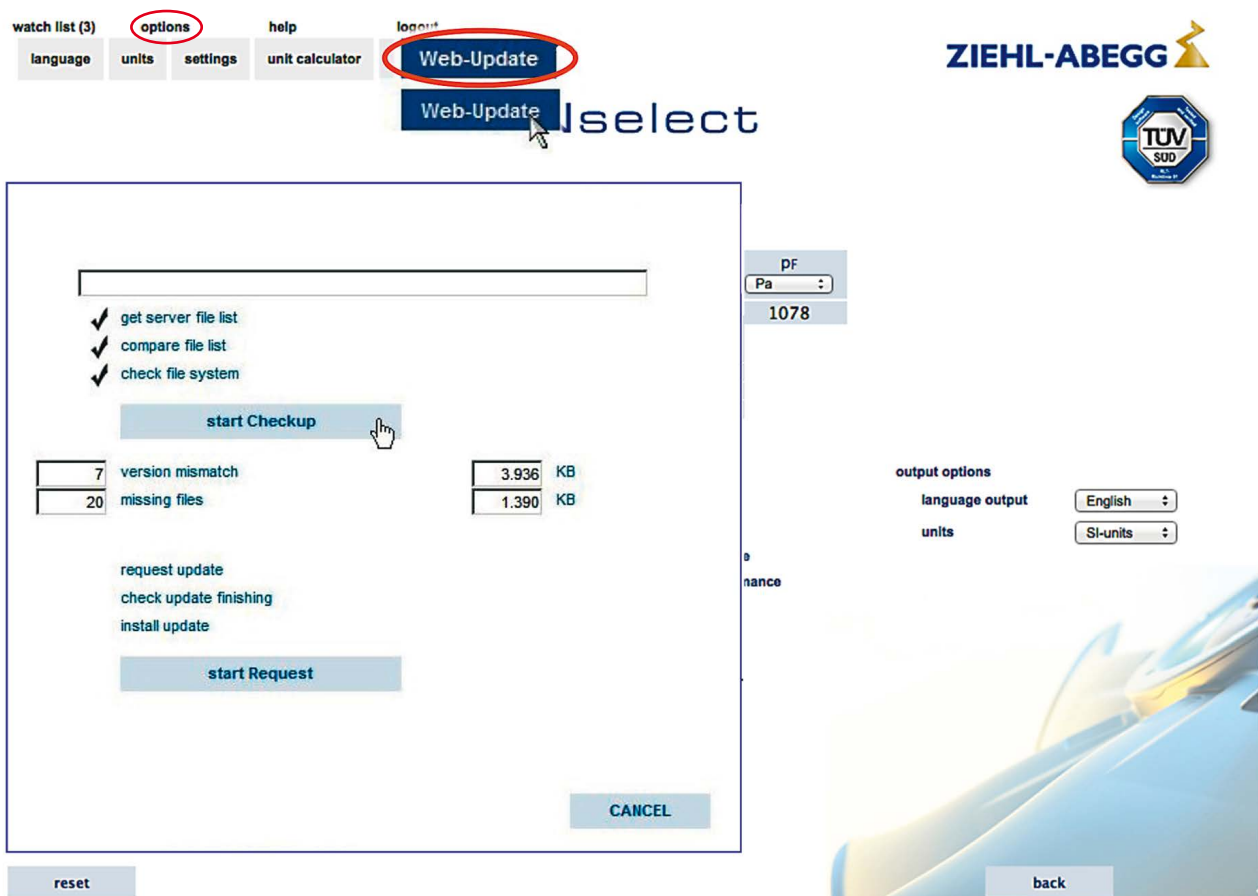

Figure 25: Web update

10. General Notes

10.1. Notes on Product Portfolio, Acoustics and Performance Data

The continuous line in the characteristic field represents the optimal and permissible operating range of fans.

The user is obliged to check whether any add-on parts may be required prior to ordering. Required ordering information: Article number and type designa-

tion [Example: 138299 (FN080-ADA.6N.V7)]

All sound and noise data contain a tonal noise part due to the measurements used. Other allowances or equipment influences are not considered unless the appropriate option is selected.

10.2. ErP Directive

By adopting the Kyoto Protocol, the European Union committed itself to reducing CO₂ emissions by at least 20% by 2020. One measure introduced to achieve this goal is the EuP Directive (Energy using Products-Directive) passed by the EU in 2005 and renamed ErP Directive (Energy related Products-Directive) in 2009 which is also known in Germany as the Ecological Design Directive.

The ErP execution measure for fans defines minimum efficiencies for fans in the performance range from 125 Watts to 500 kW, so that no "energy gluttons" will be marketed in Europe in the future. The ErP Directive is being implemented in two stages: Stage 1 in 2013 and Stage 2 in 2015. This gives energy efficiency the same standing as compliance with the Low Voltage or EMC Directive. The system efficiency requirement is a prerequisite for CE certification and is thus essential for a product to be used in EU member states. Labelling such as for refrigerators or washing machines is not planned for fans because the fan manufacturers

usually have no influence over the installation conditions.

The identifiers ErP2013 and/or ErP2015 indicate that a fan meets the minimum efficiency factors of the respective level according to the ErP directive. The actual efficiency in the energy efficiency optimum of the fan which is used for the ErP evaluation is called η_{statA} . In order to meet ErP requirements, this efficiency must reach a certain minimum value (target energy efficiency). The efficiency N is a parameter in the calculation of the target energy efficiency of the ErP directive. As a reference value for the necessary efficiency factor N_{target} we also give the actual efficiency factor N_{ACTUAL} related to a motor input power of 10kW.

10.3. Notes on TUEV Certification of the Program

Certification of the FANselect selection software by the TUEV-Süd refers to the calculatory reproduction of the measured data saved in the program (e. g. airflow, pressure increase, speed and power consumption) as well as their further calculation results and output. The accuracy class 0 in accordance with DIN 24166 cited in the certificate defines the maximum deviations of the programmed calcu-

lations from the reference measurements made on TUEV-certified test benches that occur.

The product-related delivery classes in accordance with DIN 24166 of the individual ZIEHL-ABEGG product series remain totally unaffected by this.

10.4. General

The information and data contained here have been compiled to the best of our knowledge and do not release you from the obligation to check the suitability of the products contained therein for your intended application.

ZIEHL-ABEGG SE reserves the right to make dimensional and constructional modifications in the interests of technical progress. Necessary corrections to the catalogue data will be updated continuously.

These products are sold subject to the Technical Terms of Delivery for Fans in accordance with DIN 24 166.

The customer is obliged, insofar as he does not refer to catalogue or software data in the order, to provide the supplier with general data on the purpose, type of installation, operating conditions and other conditions to be taken into consideration.

10.5. Copyright

ZIEHL-ABEGG SE holds the sole protection rights – especially copyrights – to the drawings, data and software (including but not restricted to any illustrations, photographs, animations, videos, audios, music, text and “Applets” contained in the software product), the printed supplementary material and all copies of the software product. The drawings, software and data are protected by copyright law as well as by other laws and agreements on intellectual property. The user will respect these rights, and especially shall not remove alphanumeric identifications, marks and copyright notes from the software as well as from drawings and data. §§ 69a ff. of the copyright law otherwise remain unaffected.

Above and beyond the expressly granted right to use here, the user is not granted any further rights of any kind, especially commercial protection rights such as patents, utility models or brands nor is ZIEHL-ABEGG SE obliged to grant such rights.

These conditions of use also apply for all updates provided by ZIEHL-ABEGG SE. ZIEHL-ABEGG SE is not obliged to provide the user with updates however.

10.6. Liability for Legal and Material Defects / Other Liability

Liability of ZIEHL-ABEGG SE for material and legal defects in the drawings and data as well as the drawings, especially for their correctness, freedom from error, freedom from protection rights and copyrights of third parties, completeness and/or usefulness is excluded except in case of wilful intent or malice.

Any other liability of ZIEHL-ABEGG SE is excluded unless they are legally liable, for example in accordance with the Product Liability Act, due to wilful intent, injury to life, limb or health, due to provision

of a guarantee, due to malicious concealment of a defect or violation of important contractual obligations. However, damage compensation due to violation of important contractual obligations will be limited to the typical, foreseeable damage unless there is a case of wilful intent or gross negligence. Liability for direct, random and indirect damages as well as for damage claims for lost profits – insofar as legally permissible – is totally excluded.

10.7. Privacy

The current privacy statement can be found on our website at <https://www.ziehl-abegg.com/de/en/privacy/>

11. Technical Notes

11.1. Explanation of Technical Details

Conversion factors

Pressure

		SI-unit	Additional units		
		Pa (N/m ²)	mbar	in.wg	psi (lbs./in ²)
SI-unit	Pa (N/m ²)	1	0.01	0.004015	0.000145
Other units	mbar	100	1	0.401463	0.014503
	in.wg	249.10	2.49	1	0.036127
	psi (lbs./in ²)	6,894.76	68.95	27.68	1

Air flow

		SI-unit	Additional units		
		m ³ /s	m ³ /h	l/s	cfm
SI-unit	m ³ /s	1	3,600	1,000	2,118.9
Other units	m ³ /h	0.000277	1	0.277777	0.588583
	l/s	0.001	3.6	1	2.1189
	cfm	0.000472	1.698994	0.471943	1

Power consumption

		W	kW	hp
SI-unit	W (J/s)	1	0,001	745,99
Other units	kW	1,00	1	0.4569
	hp	0.0134102	1.4102	1

Temperature

		SI-unit	Additional units
		°C	°F
SI-unit	°C	1	(°C × 1.8) + 32
Additional units	°F	(°F – 32) / 1.8	1

11.2. Aerodynamics and Acoustics

Measurement method

The characteristic field display shows the pressure increase Δp_{sF} in Pa as a function of the air flow q_v in m^3/h .

Technical terms of delivery

The specified performance data correspond to accuracy class **3** in accordance with **DIN 24 166** and apply for reference data and air handling capacity curves at reference voltage. The continuous line in the characteristic field represents the optimal and permissible operating range of axial fans.

Fan test bench

FE2owlet-ECblue, FE2owlet:

The fan performance curves are determined on a combined air and noise test bench.

The performance curves are measured according to **DIN EN ISO 5801** or **AMCA 210-99**. The acoustic power levels are measured according to **DIN EN ISO 3745** and **ISO 13347-3** by the enveloping surface method.

The figure below shows an example of a measurement set-up. The fan is mounted on the measuring chamber with free intake and free blow out (installation type A according to **DIN EN ISO 5801** or **AMCA 210-99**).

Air density

The air temperature and humidity are conditioned and largely held constant during the measurement. The characteristic curves shown refer to the measuring density. The mean measuring density is 1.6 kg/m^3 .

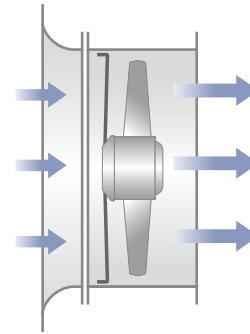

KL-1290a

Installation type A according to ISO 5801



Technology Centre (InVent)

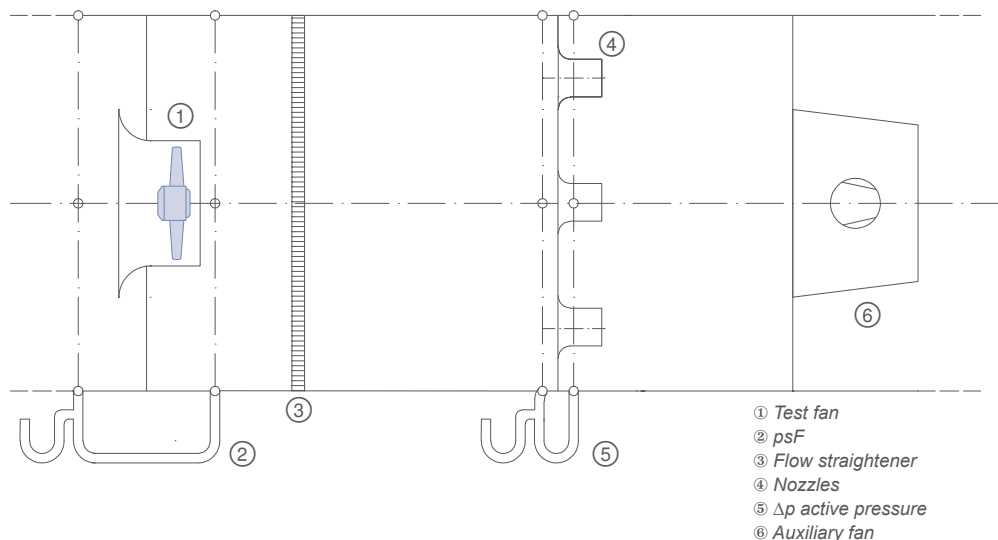

11.3. Noise Level Data

The catalogue consistently specifies the intake side, A-evaluated acoustic power level L_{WA} . The acoustic power regulations follow the enveloping area method in accordance with ISO 13347-3, accuracy class 1 and/or DIN EN ISO 3745.

For this, the acoustic pressure level L_p of the individual third-octave bands is measured at 12 points on the enveloping area (fig. 1a). The measured acoustic pressure levels for the third-octave bands are initially used to calculate the acoustic power level for the third-octave bands and then the intake side acoustic power level L_W . To do this, the fans are installed with a free intake (from the measuring chamber) and blow out (to the surroundings). The standard measurements are made without additional add-on parts such as screen protection against accidental touching. The used measuring instruments comply with DIN EN 61672.

The A-evaluation normally made causes the subjective human noise perception to be considered due to the different weighting of the third-octave sound power levels. The A-evaluated acoustic power level is the normal variable for evaluating the noise behaviour of technical devices.

Calculation of the pressure side acoustic power level and the total acoustic power level

The pressure side acoustic power level is approximately the same as the intake side for axial fans. The total acoustic power level is calculated from adding the power from the intake and pressure side acoustic power level (see DIN 45 635 Part 1, Appendix F, DIN EN ISO 3745). Thus, it is approximately 3 dB higher than the intake side acoustic power level specified in the catalogue.

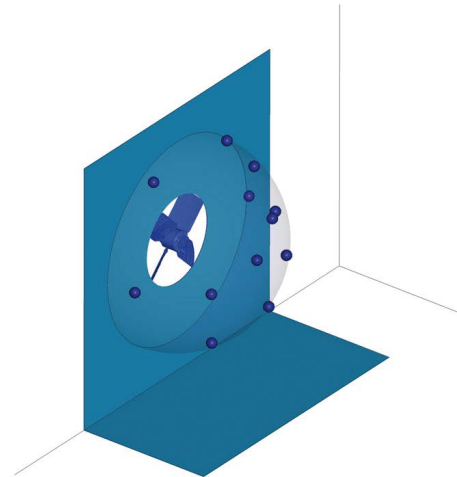

Fig. 1a: Microphone positions of fan

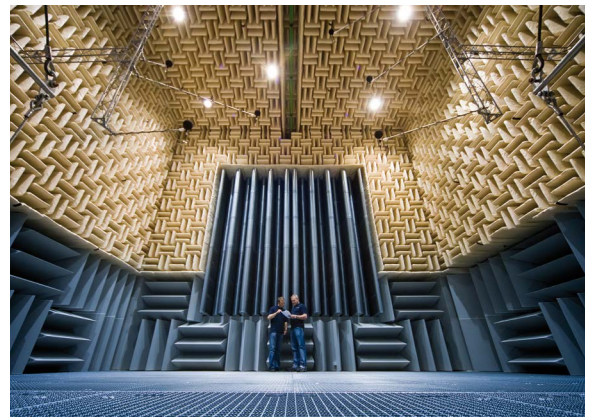

Fig. 1b: Test bench

Determination of the total acoustic power level when several sound sources are interacting

The total acoustic power level of several individual interacting sound sources is given by the power addition of the individual levels according to DIN EN ISO 3745. This relation forms the basis for the charts in figs. II and III.

For the addition of several sound sources of the same level the total level in the chart in fig. II can be read directly, an interaction of e.g. 6 identical sound levels therefore causes an approximately 8 dB higher total level.

The total acoustic power level of two sound sources with different levels can be read from the chart in fig. III. Two sound sources with acoustic power levels that differ by 4 dB, for example, create a total acoustic power level which is about 1.5 dB higher than that of the louder sound source.

Determination of the acoustic pressure level

The A-evaluated acoustic pressure level L_{pA} is calculated for rooms with average absorption capacity for a distance of 1 m from the fan axis, by deducting 7 dB from the A acoustic power level L_{WA} . This assumption is applicable with sufficient accuracy in most cases. The noise behaviour can, however, be heavily influenced by the individual installation situation.

The distance-dependent reduction in the acoustic pressure level at partial reflection is shown in fig. IV.

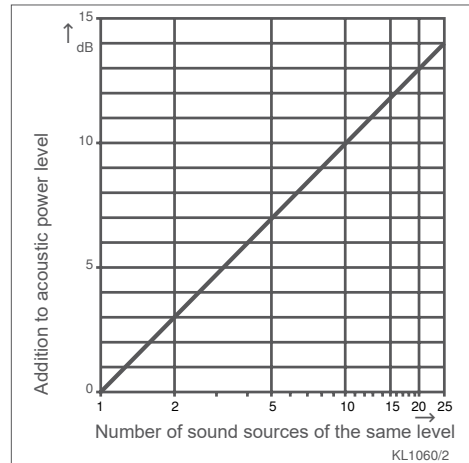

Fig. II: Addition of several sound sources

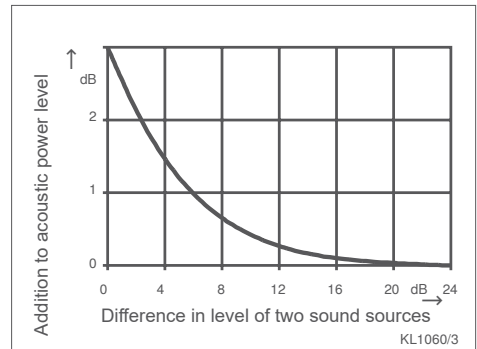

Fig. III: Sound sources of different levels

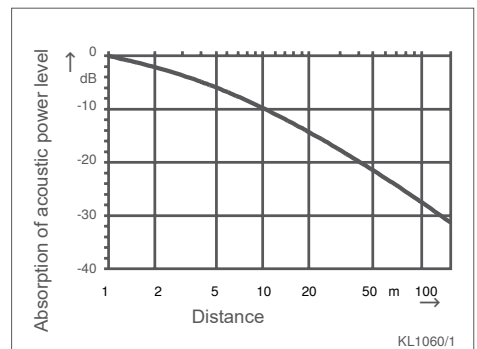

Fig. IV: Absorption of the acoustic pressure level

11.4. Electrical Connection and Motor

Fan drive

The external rotor motor in three-phase AC version (3~) or single-phase AC version (1~) integrated into the fan hub complies with the regulations for rotating electrical machines according to DIN EN 60 034-1 (VDE 0530 Part 1). AC technology: The reference voltage for three-phase AC motors is 400 V, for single-phase AC motors 230 V. EC technology:

The centrifugal fans with ECblue technology are driven by a highly efficient EC motor with integrated commutation electronics. The ECblue motors have a wide voltage range depending on the version.

1~ 200-277 V, 50/60 Hz

3~ 200-240 V, 50/60 Hz

3~ 380-480 V, 50/60 Hz

Electrical connection

Voltage

The three-phase AC motors or single-phase AC motors are suitable for 400 V \pm 10 % or 230 V \pm 10 % as well as for 50/60 Hz. Please see the data sheet.

Motor connection

Line connection by terminal box or connecting cable according to drawings. Cable length tolerance \pm 3 cm.

Terminal box

The terminal boxes are made of impact-proof, weather-resistant plastic or diecast aluminium. All terminal boxes have two M20x1.5 cable insert openings.

Connecting cable

Heat-resistant, UV-resistant, halogen-free hoses are used, labelled by a colour code or connection designations. The wiring complies with VDE 0282 Part 804 and is suitable for operating voltages up to 690 V.

Temperature resistance -50 to +150 °C. The connection ends are stripped 10 cm and fitted with wire end ferrules.

Service capacitor

See chapter System Components.

Operation on the frequency inverter

ZIEHL-ABEGG centrifugal fans are suitable for operation with frequency inverters when the following points are observed:

All-pole active sine filters (sinusoidal output voltage! phase to phase, phase to PE conductor) as supplied by some inverter manufacturers must be installed. Request our Technical Information L-TI-0510.

du/dt filters (also called motor or suppression filters) cannot be used in place of sinusoidal filters. When using sinusoidal filters, screened motor leads, metal terminal boxes and a second earth connection to the motor can, if necessary, be omitted.

11.5. Installation and Usage Information

Measuring device for determining air volume

The active pressure process compares the static pressure before the inlet nozzle with the static pressure in the inlet nozzle at the place of greatest constriction (lowest free nozzle cross sectional area). Using the energy conservation principle, the active pressure (differential pressure of the static pressures) can be assigned to the air flow as follows:

Under normal conditions at 20°C: Under fluctuating air conditions:

$$q_v = k \cdot \sqrt{\Delta p_w}$$

$$q_v = \sqrt{\frac{\rho_{20}}{\rho_{BP}}} \cdot k_{20} \cdot \sqrt{\Delta p_w}$$

- q_v Air flow in m³/h
- Δp_w Differential pressure of the static pressures in Pa
- k Factor for specific nozzle properties, nozzle factor
- ρ_{20} Standard air density with 1.2 kg/m³
- ρ_{BP} Air density at current duty point in kg/m³

Nozzle coefficients

Size	Cpro-ECblue	Vpro-ECblue/Vpro	M-series
225			57
250	60		68
280	75	86	86
315	95	112	96
355	121	144	142
400	154	180	172
450	197	220	217
500	252	291	274
560	308	360	
630	381	445	

* $\rho = 1.20 \text{ kg/m}^3$

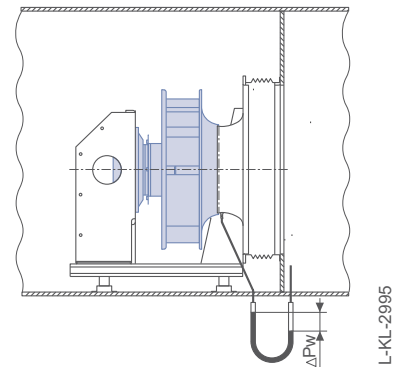

Example:

If an active pressure of 700 Pa is measured for size ER63C, the air flow can be calculated with the simplified formula as follows:

$$q_v = k \cdot \sqrt{\Delta p_w} = 381 \cdot \sqrt{700} = 10080 \text{ m}^3/\text{h}$$

The corresponding active pressure/air flow performance curves can be downloaded from our Web site in the Download section under Product Information.

The nozzle factors (k-factors) have been determined under laboratory conditions with an undisturbed flow. If intake guard grilles are used (fitted in front of the inlet nozzle), these nozzle factors cannot be used for air flow determination because of a change in the supply flow and other static pressures.

Notes on the measuring method

The measured values, which were determined using the active pressure method, are subject to a tolerance of +/- 8.0% as they pertain to the air flow result. Hereby, this tolerance is reached above a minimum air velocity of approx. 9.0 m/s at the place of greatest constriction. The tolerances are not clearly quantifiable below this minimum air velocity.

This air flow measuring method is not suitable for on-site sample measurements. A counter calibration of the air flow to the active pressure measurement must be performed on site for a more exact air flow determination in the existing installation situation. The nozzle factors determined during this process apply exclusively to this installation setup.

Installation instructions

Distances from other parts

Intake side distance: $LA \geq 0,5 \times DSa$
with disturbed flow
(e.g. intake side manifold, flaps, etc.):
 $LA \geq 1 \times DSa$

Pressure side distance: $LA \geq 1 \times DSa$

Housing wall distances: $A \geq 1.8 \times DSa$; $A = B$

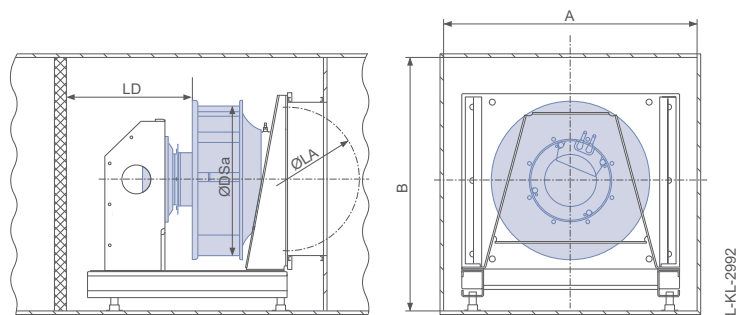

Additional baffle plates must be fitted in the suction chamber over the whole width of the AHU if there is a 90° change of direction before the intake.

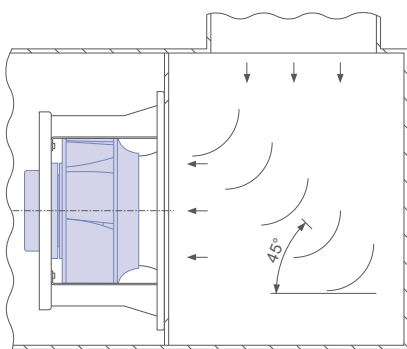

Baffle plates as a 1/4 circle

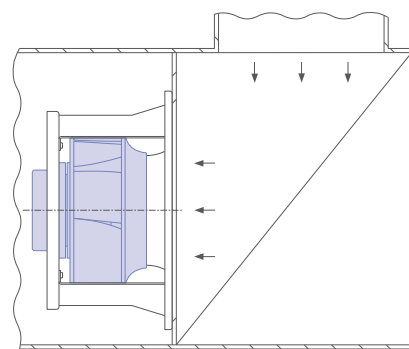

Baffle plate as a sheet metal mounted at an angle

Materials and corrosion protection

Axial fans FE2owlet-ECblue and FE2owlet have a flywheel made of high performance composite material or aluminium which is pressed onto the rotor.

The axial fans FB have a stamped steel or aluminium sheet blade which is riveted or bolted to the rotor of the external rotor motor depending on the motor size. The rotor and stator flanges are made of sea water-resistant diecast aluminium alloy. FC axial fans are made of diecast aluminium painted with one coat.

The fan nozzles are made of hot galvanised fine sheet metal.

Let us know the area of application with increased

climatic stress or use in wet rooms such as breweries, cheese dairies etc.

Additional painting possible on request at a surcharge.

Motor suspensions are manufactured, depending on the fan size, as wire grilles or a welded assembly.

The wire grille as well as the welded assembly with flat steel struts are coated with weather-resistant plastic.

Installation position

The axial fans are essentially suitable for all installation positions.

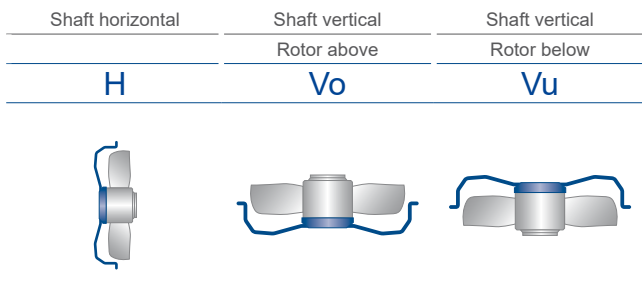

Application conditions and life endurance

Protective device

The fans may only be operated when they are installed as intended, and when safety is ensured by protective devices according to DIN EN 294 or ISO 13852 (DIN EN ISO 12100) or by other protection measures.

Condensation holes

The condensation hole at the bottom must be open according to the installation position Vo (rotor above) or Vu (rotor below). In installation position H, the condensation can drain off through a sealing gap between the stator and the rotor.

Mode

Continuous operation (S1)

Life endurance

The axial fan is maintenance-free due to the use of ball bearings with "lifelong lubrication". The grease lasts for approx. 30-40,000 hours in standard applications.

Contact protection

The contact protection may only be included when the scope of supply of the fan includes a motor suspension or a motor suspension with wall ring. The contact protection is on the intake or pressure side of the fan depending on the direction of conveyance. See the notes pertaining to the contact protection in the technical data sheets.

The "System components" section contains separate screen protection against accidental contact, which can be positioned on the pressure or intake side of the fan as required and depending on the installation situation, to meet the safety requirements set out in DIN EN ISO 13857. Refer to the "Influence of screen protection" section.



Axial fan FC, design Q

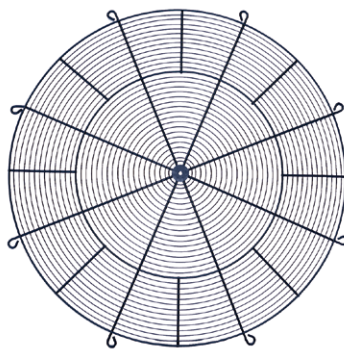

Screen protection system component, blow out side

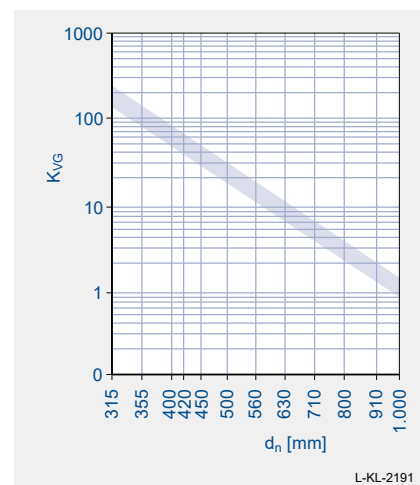

Screen loss factor K_{VG} depending on the fan nominal diameter d_n

Influence on screen protection

Safe distances against reaching danger areas

Standard DIN EN 13857 defines the safe distances against reaching danger areas with the upper limbs.

In axial fans, screen protections are preferably used as a "protective construction". The vast majority of our axial fans (S, K, D, W, Q designs) are equipped with a screen protection integrated into the suspension as standard. A separate screen protection is offered as an accessory for fan types with suspension without an integrated screen protection. The conveyed air current encounters a resistance from the screen protection which is noticeable as a pressure loss Δp_{VG} . The pressure loss Δp_{VG} grows linearly with a resistance factor ζ_G or squarely with the conveyed air flow q_v .

$$\Delta p_{VG} = \zeta_G \cdot \frac{\rho}{2} \cdot \frac{16 \cdot q_v^2}{\pi^2 \cdot d_n^4}$$

The resistance factor ζ_G is basically determined by the screen design (mesh width, ring spacing) which is prescribed by DIN EN 13857. The coefficient of resistance for the ZIEHL-ABEGG screen protections obtained in series of tests on FC series fans lies in the range $\zeta_G = 0.2-0.4$. This covers installation of the screen protection on the intake and pressure side. The following equation serves for a rough estimate of the pressure loss of the screen protection in [Pa]. $\Delta p_{VG} = K_{VG} \cdot 10^{-8} \cdot q_v^2$

The screen loss factor K_{VG} can be read from the above diagram depending on the nominal fan diameter d_n . The air flow q_v must be inserted in [m³/h].

Note:

In type FB the pressure loss due to the screen protection is already taken into consideration in the performance curve chart in short nozzle.

Installation instructions

Flow conditions

When installing fans in devices, favourable flow conditions must be maintained even in compact installation

The following installation recommendations (fig. I and II) show the necessary minimum distances.

Fig. I free intake, connected on pressure side

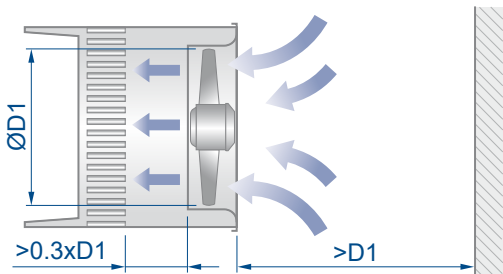

L-KL-2508

Fig. I

Fig. II free blow off, connected on intake side

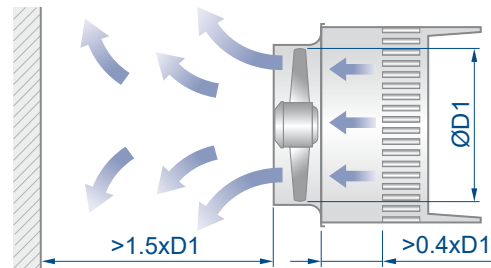

L-KL-2508/1

Fig. II

Fig. III Inlet nozzles

Observe the head gap s between the fan blade and inside edge of nozzle when installing.

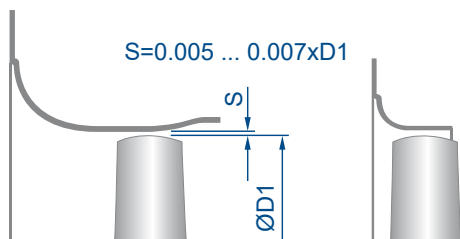

L-KL-2507

Fig. III

Fig. IV Influence of the nozzle shape, performance curve comparison (fig. IV)

- ① Full nozzle (shape Q)
- ② Short nozzle see accessories

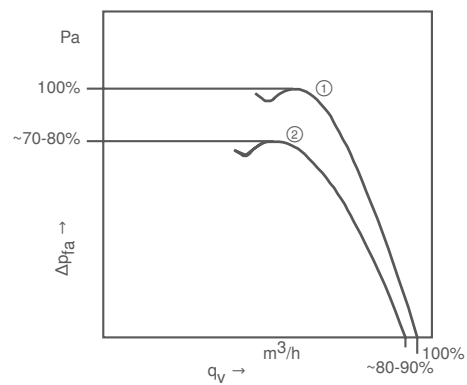

Fig. IV

Installation / application examples

Fan type FB_ _ _ _ _K

- ① Axial fan for refrigeration
- ② Device rear panel with short nozzle

Space saving type by rear panel with short nozzle.
Lower performances are to be expected when using short nozzles.

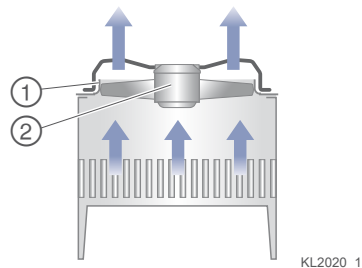

Example: Application with short nozzle for refrigeration

Fan type FN_ _ _ _ _Q

- ① Axial fan for refrigeration
- ② Wall ring plate or device rear panel with full nozzle

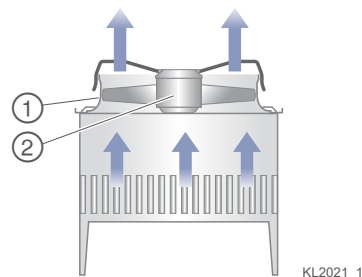

Example: Application with full nozzle for refrigeration

Fan type FN_ _ _ _ _W

- ① Axial fan for heating technology
- ② Device rear panel

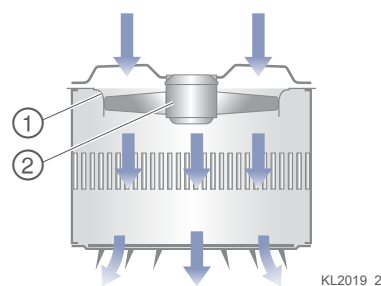

Example: Application with short nozzle for air heater

Examples of application



Small refrigeration units with ZIEHL-ABEGG Condenser with axial fans



Condenser with axial fans

12. Explanation of terms

12.1. Formula Symbols and Units

Symbol	Units	Description
type		Fan type key
article no.		Article number
size		Size
C_{400V}	μF	Capacitor capacitance
f_{DP}	Hz	Operating frequency
f_{max}	Hz	Maximum frequency
f_{rated}	Hz	Rated frequency
H	m	Installation height
I_{DP}	A	Current in duty point
I_{rated}	A	Rated current
IA	A	Starting current
IP	–	Protection class IP
k	–	k-factor nozzle pressure
L_{w5}	dB	Intake side acoustics
L_{w6}	dB	Pressure side acoustics
L_{wA5}	dB	Intake side acoustics, A-weighted
L_{wA6}	dB	Pressure side acoustics, A-weighted
M	kg	Weight
Mn_{rated}	Nm	Motor torque
n_{DP}	1/min	Speed in duty point
n_{max}	1/min	Maximum fan speed
n_{rated}	1/min	Rated motor speed
N_{ACTUAL}	–	Actual efficiency of the fan at the energy efficiency optimum related to the motor input power 10kW
n_N	1/min	Rated motor speed
N_{target}	–	Required efficiency at motor input power 10kW
P_1	kW	Electrical power consumption without control (nominal data)
P_{1DP}	kW	Electrical power consumption without control (duty point)
P_{1rated}	kW	El. power consumption without control
$P_{1max DP}$	kW	Max. electrical power consumption without control (duty point related)
P_{2rated}	kW	Rated motor power output

p_{d2}	Pa	Dynamic pressure
$p_{d2\text{ BP}}$	Pa	Pressure increase in the duty point, dynamic
p_F	Pa	Pressure increase in the duty point, total
$p_{F\text{ DP}}$	Pa	Pressure increase in the duty point, total
$p_{F\text{ mains}}$	Pa	Pressure increase in mains operation, total
P_L	kW	Impeller power input
$P_{L\text{ max}}$	kW	Max. impeller power input
P_N	kW	Rated motor power
p_{sF}	Pa	Pressure increase in the duty point, static
$p_{sF\text{ nozzle}}$	Pa	Differential pressure nozzle
$p_{sF\text{ mains}}$	Pa	Pressure increase in mains operation, static
P_{SFP}	W/(m ³ /s)	Power consumption value SFP
P_{sys}	kW	System power consumption incl. control
$P_{\text{sys rated}}$	kW	System power consumption incl. control
q_V	m ³ /h	Air flow in duty point
$q_{V\text{ mains}}$	m ³ /h	Air flow in mains operation
SFP	–	SFP class
THCL	–	Temperature class THCL
tr	°C	Ambient temperature
$t_{R(\text{max})}$	°C	Min. admissible ambient temperature
$t_{R(\text{min})}$	°C	Min. admissible ambient temperature
U_{DP}	V	Voltage in the duty point
U_{rated}	V	Rated voltage
ΔI	-	Current increase
η_F	%	System efficiency, total without control
$\eta_{F\text{ sys}}$	%	System efficiency, total with control
$\eta_{F\text{ sys mains}}$	%	System efficiency, total in mains operation
η_{FL}	%	Impeller efficiency, total
$\eta_{FL\text{ mains}}$	%	Impeller efficiency, total in mains operation
η_{sF}	%	System efficiency, static without control
$\eta_{sF\text{ sys}}$	%	System efficiency, static with control
$\eta_{sF\text{ sys mains}}$	%	System efficiency, static in mains operation
η_{sFL}	%	Impeller efficiency, static
$\eta_{sFL\text{ mains}}$	%	Impeller efficiency, static in mains operation
η_{statA}	%	Total efficiency, statically according to measuring category A in the optimal point without losses of the electronic speed control, according to calculation method ErP directive no. 327/2011 Appendix II
$\eta_{M\text{ rated}}$	%	Motor efficiency
ρ	kg/m ³	Density

12.2. Type Key

Axial fans

Required order information

Type designation and article number

Example

Type: FN050-4EQ.4I.A7P1
Article no.: 140084

Example

FN 050 - 4 E Q . 4I . A 7 P 1

Axial fan									
	FB								
	FC								
	FN								
Fan size									
Impeller diameter 450 mm	045								
Impeller diameter 500 mm and so on	050								
Polecount									
2 pole	2								
4 pole	4								
4-4 pole	V								
6 pole	6								
6-6 pole	S								
8 pole	8								
8-8 pole	A								
10 pole	Z								
10-10 pole	M								
12-12 pole	N								
Type of current									
three phase alternating current	D								
single phase alternating current	E								
External rotor EC motor with controller	I								
Fan design									
without mounting parts	A								
Full nozzle									
rectangular	Q								
round	L								
Pipe socket									
	H								
Flange ring									
	F								
Axial screwed suspension									
for full nozzle Q and L / conveying direction A	D								
for short nozzle E / conveying direction A	W								
for short nozzle E / conveying direction V	K								
	I								
nozzle Q or L									
Centrifugal screwed suspension									
On outer diameter for full nozzle Q or L /	S								
Motor									
Airflow direction									
Intake over stator	A								
Blow off over stator	V								
Number of blades									
	7								
Blade angle									
	P								
Blade index									
	1								

Centrifugal fans in general

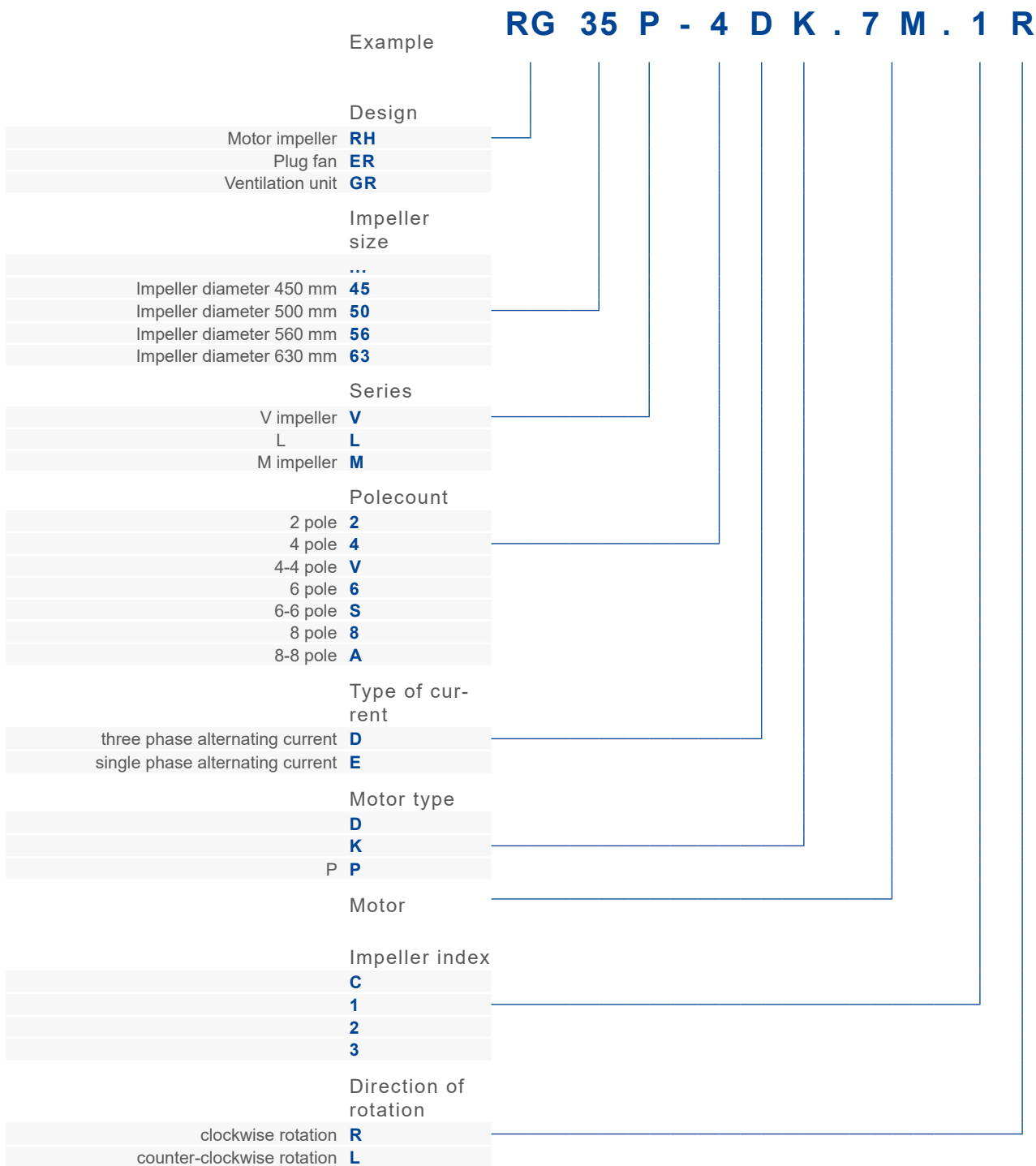

Required order information

To be specified when ordering: Type, article no. and part no. system components if applicable

Example

Type: RH50V-4DK-6K.1R
 Article no.: 113290

Type key ECblue

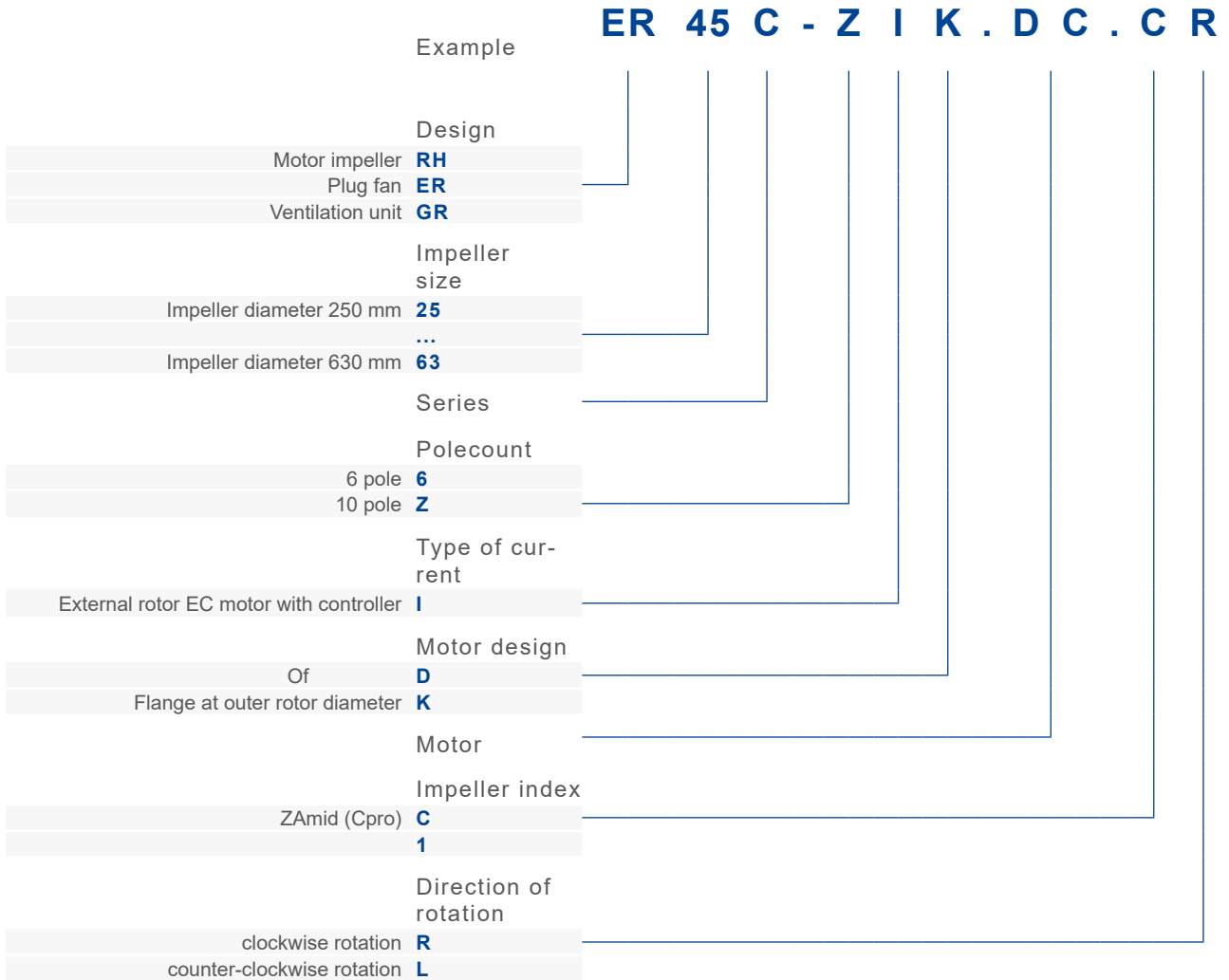

Required order information

To be specified when ordering: Type, article no. and part no. system components if applicable

Example

Type: ER45C-ZIK.DC.CR,
Article no.: 114596/A01

12.3. Definition of Performances and Efficiencies

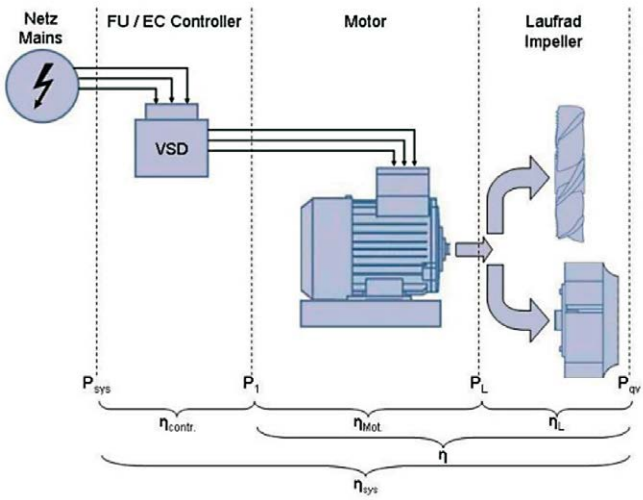

Figure 29 Impeller with ILM + controller

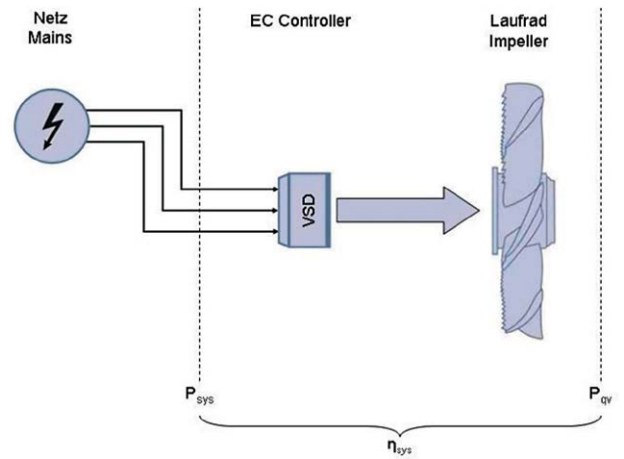

Figure 30 Impeller with ALM + controller

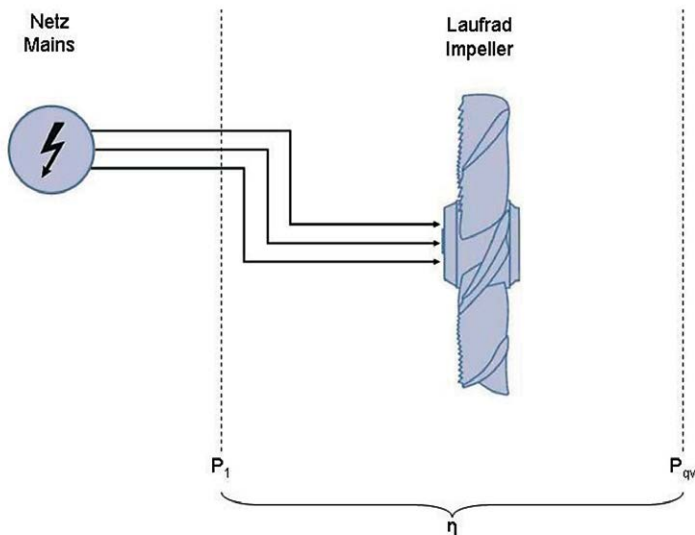

Figure 31 Impeller with ALM

12.4. Definition of the Main Dimensions

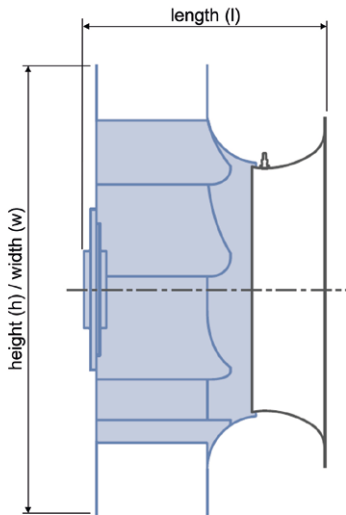

Figure 32 Dimensions for impellers

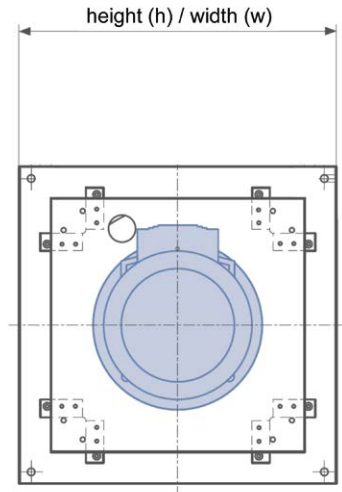
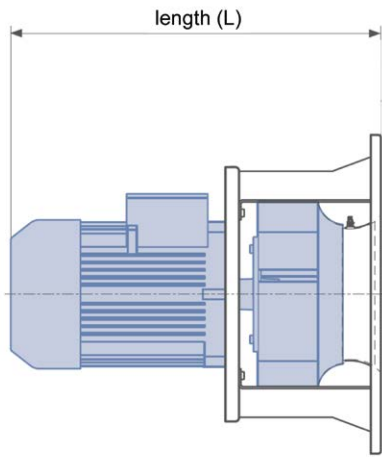

Figure 33 Dimensions of GR fans

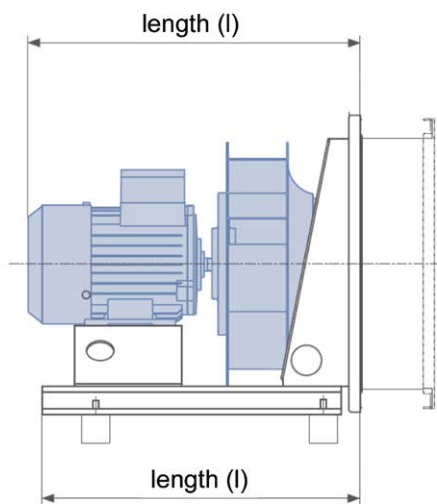
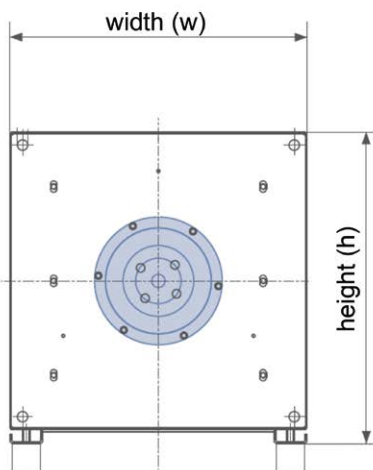

Figure 34 Dimensions of ER fans

14. Documentation of the FANselect.dll

(valid as of Version 1.01)

Contents:

1. General
2. DLL functions
3. Requests to the FANselect.dll
4. Summary request parameters
5. Summary output parameters

14.1. General

Communication with FANselect.dll takes place via request string and reply string. The format used is JSON (JavaScript Object Notation).

Compact – Info about JSON format:

An object begins with the '{' character and is ended by '}'. The data in an object are pairs of text key and value which are separated by ':'.

```
{ "qv": 2000, "psf": 250 }
```

An array begins with the '[' character and is ended by ']'. The individual values are separated by commas: [10, 20, 30] or also ["aaa", "bbb", "ccc"]

A value may also be an object or an array apart from a string or number.

```
[
  { "qv": 2000, "psf": 250 },
  { "qv": 2500, "psf": 150 },
  { "qv": 2500, "psf": 175 }
]
```

This array of 3 objects corresponds in principle to the result format of the fan search.

Requests to the FANselect.dll are always made as an object. This object must not be completely filled with all maximum possible data.

The search for fans only works after a successful login. This login should be made with the 1st request and is then no longer necessary (the login data can always be sent however).

```
{ "username": "XYZ",
  "password": "ABC",
  ...
}
```

14.2. DLL Functions

The FANselect.dll can be addressed by 3 different functions. The difference between these functions is the string type.

Prototype declaration (static bonding):

```
external "C"
{
  __declspec(dllimport)
  const char* __stdcall ZAJsonRequestA(const char *szReq);

  __declspec(dllimport)
  const wchar_t* __stdcall ZAJsonRequestW(const wchar_t *szReq);

  __declspec(dllimport)
  const BSTR __stdcall ZAJsonRequestBSTR(BSTR sReq);
}
```

14.2.1. ZAJsonRequestA

The **ZAJsonRequestA** function uses Utf-8 coded strings.

Calling ZAJsonRequestA with C++:

```
std::string sRequest;
...
std::string sResult = ZAJsonRequestA( sRequest.c_str() );
```

Calling ZAJsonRequestA with VisualBasic .NET:

Declare Function ZAJsonRequestA Lib "FANselect.dll" (ByVal sRequest As String) As String

```
Dim sRequest As String
Dim sResult As String
...
sResult = ZAJsonRequestA(sRequest)
```

14.2.2. ZAJsonRequestW

The ZAJsonRequestW function uses Unicode strings.

Calling ZAJsonRequestW with C++:

```
std::wstring sRequest;
...
std::wstring sResult = ZAJsonRequestW( sRequest.c_str() );
```

14.2.3. ZAJsonRequestBSTR

The ZAJsonRequestBSTR function uses OLE strings.

Calling ZAJsonRequestBSTR with Excel-VBA:

Declare Function ZAJsonRequestBSTR Lib „FANselect.dll“ (ByVal sRequest As String) As String

```
Dim sRequest, sResult As String
...
Dim vaRequest, vaResult As Variant
vaRequest = StrConv(sRequest, vbUnicode)
vaResult = ZAJsonRequestBSTR(vaRequest)
sResult = StrConv(vaResult, vbFromUnicode)
```

14.3. Requests to the FANselect.dll

14.3.1. Fan Search “search”

The main functions are set by the “cmd” parameter and require further data depending on the function. At least the desired duty point is required in addition to the “search” for the fan search.

Minimum request for fan search:

```
{ "cmd": "search"
  "qv": "3000",
  "psf": "200"
}
```

If it is the 1st request, the login data must also be entered:

```
{ "cmd": „search“,
  "qv": "3000",
  "psf": "200",
  "username": "XYZ",
  "password": "ABC"
}
```

Parameters for the fan search:

qv	Air flow [m3/h]
psf	Static pressure [Pa]
pf	Total pressure [Pa]

The parameters “psf” and “pf” should not be used together of course. If both parameters contain values, a static pressure search is made. (A summary of all request parameters can be found in chapter 4.)

When setting the “unit_system” parameter: “i”, imperial units (ft³/min, Inch, in.Wg.,...) are used for the request and respond parameters. If the parameter is not set or “m” is set, metric units (m³/h, mm, Pa,...) are used.

Optional search parameters:

product_range	Product groups ID
fan_type	Type key complete or as partial string (wildcard character: "?" – for exactly one character; "*" – for any number of characters)
article_no	Article number complete or as partial string (wildcard character: "?" – for exactly one character; "*" – for any number of characters)
fan_size	Size [mm] (search over several sizes with " " separation possible, e.g. 315 450 630)
mains_operation	Controlled or uncontrolled operation (FU, MAINS)
motor_technology	Motor technology (AC, EC, DC)
current_phase	Current type (1~, 3~)
nominal_frequency	Line frequency [Hz]
voltage	Line voltage [V]
search_tolerance	Search tolerance [%]
motor_safety_margin	Motor safety margin [%]
airflow_volume_reserve	Airflow volume reserve [%]
air_density	Density of conveyor [kg/m ³] (The density conversion is only made for centrifugal fans with inside rotor or ECblue motors; otherwise output: "[]")
ambient_temperature	Ambient temperature [°C]
grill_influence	Grille influence
installation_height_mm	Installation room height [mm]
installation_width_mm	Installation room width [mm]
installation_length_mm	Installation room length [mm]
protection_class	Protection class IP
erp_class	ErP class
sfp_class	SFP class (1-7)

An array of fan objects is delivered as a result:

```
[{ Fan 0 },
 { Fan 1 },
 { Fan 2 },
 ...
]
```

Definition of the type IDs:

Group	Subgroup	Designation	BR_ID
Product groups	EC fans	All EC fans	BR_01
Product groups	EC fans	FE2owlet-ECblue with ZAplus	BR_52
Product groups	EC fans	FE2owlet-ECblue	BR_02
Product groups	EC fans	Vpro-ECblue	BR_04
Product groups	EC fans	Cpro-ECblue	BR_39
Product groups	EC fans	C-ECblue	BR_03
Product groups	AC fans	All AC fans	BR_06
Product groups	AC fans	FE2owlet with ZAplus	BR_55
Product groups	AC fans	FE2owlet	BR_07
Product groups	AC fans	MAXvent owlet	BR_43
Product groups	AC fans	Vpro	BR_10
Product groups	AC fans	Cpro	BR_08
Product groups	AC fans	C	BR_09
Product groups	AC fans	C-ATEX	BR_36
Fan types	Axial fans	All axial fans	BR_11
Fan types	Axial fans	FE2owlet-ECblue with ZAplus	BR_53
Fan types	Axial fans	FE2owlet-ECblue	BR_12
Fan types	Axial fans	FE2owlet with ZAplus	BR_54
Fan types	Axial fans	FE2owlet	BR_13
Fan types	Axial fans	MAXvent owlet	BR_44
Fan types	Centrifugal fans	All centrifugal fans	BR_14
Fan types	Centrifugal fans	Vpro-ECblue	BR_16
Fan types	Centrifugal fans	Vpro	BR_19
Fan types	Centrifugal fans	Cpro-ECblue	BR_40
Fan types	Centrifugal fans	Cpro	BR_17
Fan types	Centrifugal fans	C-ECblue	BR_15
Fan types	Centrifugal fans	C	BR_18
Fan types	Centrifugal fans	C-ATEX	BR_37
Branch spec. fans	RLT equipment fans	All RLT fans	BR_21
Branch spec. fans	RLT equipment fans	Cpro-ECblue	BR_38
Branch spec. fans	RLT equipment fans	Cpro	BR_26
Branch spec. fans	RLT equipment fans	C-ECblue	BR_22
Branch spec. fans	RLT equipment fans	C	BR_27
Branch spec. fans	RLT equipment fans	C-ATEX	BR_35

Several types can be combined with the separator '|'.
For example : "product_range" : "BR_15|BR_18|BR_36|..."

A fan object has the following format for example:

(All output parameters which appear in the Dll are explained in chapter 5.)

```
{
"ARTICLE_NO": „ 113662/O01“,
"CALC_AIR_DENSITY" : 1.16,
"CALC_ALTITUDE" : 213,
"CALC_NOZZLE_PRESSURE" : 89,
"CALC_N_RATED" : 45,
"DENSITY_INFLUENCE" : „Measuring density“,
"DRAWING_FILE" : „...\\DummyKlischeeRadial.jpg“,
"ERP_CLASS" : „2015“,
"INDEX" : 0,
"INSTALLATION_HEIGHT_MM" : 600,
"INSTALLATION_LENGTH_MM" : 346,
"INSTALLATION_WIDTH_MM" : 600,
"IS_EC" : „1“,
"KFACTOR" : 220,
"NOZZLE_GUARD" : „Measured in standard nozzle in
Installation type A according to ISO 5801“,
"PRODUCT_IMG" : "C:\\...\\Vpro-ECblue.jpg",
"TYPE" : "GR45V-ZIK.DC.1R",
"ZA_BG" : "450",
"ZA_ETAF_SYS" : 41.86,
"ZA_ETAF_SYS_MAINS_OPERATED" : 54.29,
"ZA_ETASF_SYS" : 37.56,
"ZA_ETASF_SYS_MAINS_OPERATED" : 48.72,
"ZA_I" : 0.44,
"ZA_LW5" : 64.99,
"ZA_LW6" : 64.83,
"ZA_LWA5" : 52.76,
"ZA_LWA6" : 56.84,
"ZA_MAINS_SUPPLY" : „1~ 230V 50Hz „,
"ZA_N" : 649.15,
"ZA_NMAX" : 1,440,
"ZA_PD" : 6.15,
"ZA_PF" : 59.86,
"ZA_PF_MAINS_OPERATED" : 300.69,
"ZA_PSF" : 53.72,
"ZA_PSF_MAINS_OPERATED" : 269.82,
"ZA_PSYS" : 82.35,
"ZA_QV" : 2,072.99,
"ZA_QV_MAINS_OPERATED" : 4,646.04,
"ZA_SCHUTZGITTER" : "NO",

"ZA_SFP" : 146,
"ZA_SFP_CLASS" : „1“,
"ZA_U" : 230,
"ZA_WEIGHT" : 27.6,
}
```

Article number
Density used by the calculation
Altitude used by the calculation
Active pressure in nozzle for air flow determination
Percentage speed related to max. speed
Used density as text
Drawing
ErP class
Index search result
Height of the fan
Length of the fan
Width of the fan
EC fan
k-factor for determining the nozzle active pressure
Measuring method
Product image
Type key
Size
Total system efficiency
Total system efficiency, mains operation
Static system efficiency
Static system efficiency, mains operation
Current in the duty point
Acoustic power level Lw5
Acoustic power level Lw6
Acoustic power level Lw(A)5
Acoustic power level Lw(A)6
Mains supply
Speed in duty point
Max. speed
Dyn. pressure in duty point
Total pressure in duty point
Total pressure in mains operation
Static pressure in duty point
Static pressure in mains operation
System power consumption electrical
Air flow in duty point
Air flow in mains operation
Yes/no info for calculatory consideration of the screen protection
Specific fan power in duty point (P_{SFP})
SFP class in the duty point
Voltage in duty point
Fan weight

14.3.2. Select Fan "select"

In this request a single fan is selected from the search result or, when entering an article number, selected directly without making a search first. These two possibilities exist in all further requests.

When selecting from the search result, the appropriate index (starting with 0) is expected as a parameter in the "cmd_param" field:

```
{ "cmd": "select"
  "cmd_param": "1"           Index from the search result
}
```

This field must contain "article_no" for direct selection by an article number. If both fields contain values, the article number has priority.

```
{ "cmd": "select"
  "article_no": "113662/O01" Article number of the fan
}
```

The result of the "select" request largely corresponds to the fan object from the "search" function but contains some additional values:

(All output parameters which appear in the DII are explained in chapter 5.)

<pre>{ ... "CALC_LW5_OKT" : „ 63.02,59.30,50.41,49.76,45.19,42.35,46.26,25.26“, "CALC_LW6_OKT" : „ 61.78,58.79,54.00,53.78,52.92,46.80,46.34,25.93“, "CALC_LWA5_OKT" : „ 36.78,41.67,42.01,46.09,45.37,43.47,47.44,24.35“, "CALC_LWA6_OKT" : „ 35.53,41.82,45.43,50.38,53.06,47.85,47.52,25.04“, "CALC_PSYS_MAX" : 82, "CAPACITOR_CAPACITANCE" : „ „, "CAPACITOR_VOLTAGE" : „ „, "CHART_VIEWER_URL" : http://fanse ... "CIRCUIT" : „ „, "COSPHI" : „ „, "CURRENT_PHASE" : „1“, "EC_TYPE" : „ „, "EFFICIENCY_STAT" : „ „, "EFFICIENCY_TOT" : „ „, "INCREASE_OF_CURRENT" : „ „, "MAX_CURRENT" : "2.80", "MAX_FREQUENCY" : „ „, "MAX_TEMPERATURE_C" : "60", "MAX_VOLTAGE" : "277", "MIN_CURRENT" : "3.90", "MIN_PSF" : „ „, "MIN_TEMPERATURE_C" : "-25", "MIN_VOLTAGE" : "200", "NOMINAL_CURRENT" : „ „, "NOMINAL_FREQUENCY" : 50, "NOMINAL_SPEED" : 1,440, "NOMINAL_VOLTAGE" : „230“, "PHASE_DIFFERENCE" : „ „, "POWER_INPUT_HP" : „ „, "POWER_INPUT_KW" : „0.75“, "POWER_OUTPUT_HP" : „ „, "POWER_OUTPUT_KW" : „ „, "PROTECTION_CLASS_IP" : „IP54“, "PROTECTION_CLASS_THCL" : "THCL155", "VOLTAGE_TOLERANCE" : „ „, }</pre>	<p>Octave band Lw5 Octave band Lw6 Octave band Lw(A)5 Octave band Lw(A)6 Max. system power consumption Capacitor capacitance Capacitor voltage Url of the chart viewer Circuit Cos. Phi Type of current EC type Efficiency total Efficiency static Current increase Max. current Max. frequency Max. temperature Max. voltage Min. current Min. static pressure Min. temperature Min. voltage Nominal current Nominal frequency Nominal speed Nominal voltage Phase difference Power input HP Power input kW Power output HP Power output kW Protection class IP Protection class THCL Voltage tolerance</p>
--	--

The "CHART_VIEWER_URL" can be opened with a browser to show the performance curves and duty point of the selected fan. A server url for the chart viewer can be specified in the configuration file "catalog.xws":

```
<ZA ChartViewer_Url="http://abcd/" />
```

Without this server url, FANselect is used on the FANselect server.

14.3.3. Request nominal data "nominal_values"

With this request – like with "select" – a fan can be selected from the search result or directly by the article number. The parameter for the "cmd" field is "nominal_values"

```
{ "cmd": "nominal_values",
  "cmd_param": „1“           Index from the search result
}

{ "cmd": "nominal_values",
  "article_no": " 113662/O01", Article number of the fan
  "current_phase": "1",       (Hereby the specification of the electrical data for the
  "voltage": "230",           nominal data output is necessary because for a
  "nominal_frequency": "50"   article number there are several electrical versions.)
}
```

The unchanged nominal data of the database are delivered as a reply.

<pre>{ "ARTICLE_NO": " 113662/O01", "CAPACITOR_CAPACITANCE" : "", "CAPACITOR_VOLTAGE" : "", "CIRCUIT" : "", "COSPHI" : "", "CURRENT_PHASE" : "1", "EC_TYPE" : "", "EFFICIENCY_STAT" : "", "EFFICIENCY_TOT" : "", "INCREASE_OF_CURRENT" : 0, "MAX_CURRENT" : "2.80", "MAX_FREQUENCY" : "", "MAX_TEMPERATURE_C" : "60", "MAX_VOLTAGE" : "277", "MIN_CURRENT" : "3.90", "MIN_TEMPERATURE_C" : "-25", "MIN_VOLTAGE" : "200", "NOMINAL_CURRENT" : "", "NOMINAL_FREQUENCY" : 50, "NOMINAL_SPEED" : 1,440, "NOMINAL_VOLTAGE" : "230", "PHASE_DIFFERENCE" : 0, "POWER_INPUT_HP" : "", "POWER_INPUT_KW" : "0.75", "POWER_OUTPUT_HP" : "", "POWER_OUTPUT_KW" : "", "PROTECTION_CLASS_IP" : „IP54“, "PROTECTION_CLASS_THCL" : "THCL155", "VOLTAGE_TOLERANCE" : "" }</pre>	<pre>Article number Capacitor capacitance Capacitor voltage Circuit Cos. Phi Type of current EC type Efficiency static Efficiency total Current increase Max. current Max. frequency Max. temperature Max. voltage Min. current Min. temperature Min. voltage Nominal voltage Nominal frequency Nominal speed Nominal voltage Phase difference Power input HP Power input kW Power output kW Power output HP Protection class IP Protection class THCL Voltage tolerance</pre>
--	--

14.3.4. Request motor data "motor_data"

Data of the standard motor installed in the fan are output with this request. With this request also, a fan can be selected from the search result or directly by the article number. The parameter for the "cmd" field is "motor_data" If a fan is selected by the article number, the voltage ("voltage") and frequency ("nominal_frequency") must be defined.

The unchanged nominal data of the database are delivered as a reply.

<pre>{ "CURCUIT" : "Y", "EFFICIENCY_CLASS" : "IE2", "NOMINAL_CURRENT" : 1.68, "NOMINAL_VOLTAGE" : 400, "NUMBER_OF_POLES" : "2", "POWER_OUTPUT_KW" : 0.75, "PROTECTION_CLASS_IP" : „IP55“ }</pre>	<pre>Circuit Efficiency class Nominal current Nominal voltage Polecount Power output Protection class IP</pre>
--	--

14.3.5. Request geometry data "geo_data"

Geometry data of the selected fan are output with this function. Data are not stored for all fans at the moment, these will be completed successively. With this request also, a fan can be selected from the search result or directly by the article number. The parameter for the "cmd" field is "geo_data"

14.3.6. Request accessory article "accessories"

With this request also, a fan can be selected from the search result or directly by the article number. The parameter for the "cmd" field is "accessories"

<pre>{ "cmd": "accessories", "cmd_param": "1" }</pre>	<pre>Index from the search result</pre>
<pre>{ "cmd": "accessories", "article_no": " 130585/0F01 " }</pre>	<pre>Article number of the fan</pre>

An array with the accessory articles for the current fan is delivered as a reply. If no accessory articles are defined in the database, an empty array is delivered.

<pre>[{ "ARTICLE_NO": „02006447“, "GROUP" : "Mechanical accessory", "GROUP_ID" : "IDC_ZBH_MZB", "PRODUCT_IMG": "C:\...\jpg", "SPRING_MOT_NUMBER" : "2", "SPRING_MOT_RATE" : „17,3“, "SPRING_MOT_TYPE" : „MSN 6“, "TYPE" : "32F35", "TYPE_ID" : "32F35" }, ...]</pre>	<pre>Accessory article no. Accessory group Accessory group ID Product image Number of spring dampers motor side Spring rate spring dampers motor side Type spring damper motor side Article name Article name ID</pre>
--	--

14.3.7. Create curve chart "get_chart"

In the "get_chart" request it must be specified which chart is to be created. The image size, image format (.emf, .png) and output directory can be defined as optional parameters. Like all other files created dynamically by the FANselect.dll, the created graphics are temporary, i.e. they are deleted after about 5 minutes.

The desired chart type is set in the "cmd_param" field. The possible values at the moment are:

air_performance	air performance chart
power_input_p1	electrical power input
power_input_pl	impeller power
efficiency_sf	efficiency static
efficiency_f	efficiency total
acoustics_lwa5	acoustic power level Lw(A)5
acoustics_lwa6	acoustic power level Lw(A)6
acoustics_lw5	acoustic power level Lw5
acoustics_lw6	acoustic power level Lw6

The image size in pixels can be set with the "chart_width" and "chart_height" parameters. The standard size is 800x600 pixels.

The graphic format can be defined with the "chart_format" parameter, whereby you can selected between "png" and "emf". Standard format for the charts is "png".

Another optional parameter is "chart_dir" with which the output directory can be defined. Without specification, the normal temporary directory or a subdirectory of it is used.

Example request:

```
{ "cmd": "get_chart",
  "cmd_param": "air_performance",
  "chart_height": „480“,
  "chart_width": „640“,
  "article_no": "113662/O01",
  "psf": "50",
  "qv": "2000"
}
```

An object with the file path is given in the "CHART_PATH" field as a reply:

```
{ "CHART_FILE": "C:/.../HTMLTEMP/t334400001.png" }
```

Please note that these files are deleted again after about five minutes. If these files are to be saved permanently, they should be copied to another directory.

If the request parameter "unit_system": "i" is set, the axis labels are specified in imperial units.

14.3.8. Request status information "status"

This request requires no further parameters and only shows the name of the user and the version number.

```
{ "USERNAME": "abc",  
  "VERSION": "FANselect V 1.01 (602) (1.10.11.1)"  
}
```

14.3.9. General Request Parameters

These general parameters depend on the fan search. At the moment, there is only one such parameter, namely the language selection with the "language" field. The "language" parameter can be specified with every request.

```
{ "language" : "DE"           Language ID  
  ...  
}
```

14.4. Summary Request Parameters

A free value field means a value range or a text box such as "chart_dir". Must fields are only air flow and pressure (static or total).

Parameter	Designation	Unit	Values
language	Language ID		DE, EN, US, IT, ES, NL, CS, PL, DA, SV, FR, FI, RU, ZH, TR, PT, JA, HU
unit_system	Units system		m, i
username	User name		
password	Password		
cmd	Main function of the request		search, select, nominal_values, accessories, get_chart
cmd_param	Additional parameters		search result index, air_performance, power_input_p1/
chart_width	Chart width	Pixels	
chart_height	Chart height	Pixels	
chart_format	Chart format		png, emf
chart_dir	Chart directory		
qv		m ³ /h	
psf	Static pressure	Pa	
pf	Total pressure	Pa	
product_range	Product groups ID		
product_design	Product design		ER, GR-VU, GR-VO, GR-H
fan_type	Type key ("?" – for exactly one character; "*" – for any number of characters)		
article_no	Article number (Wildcard character: "?" – for exactly one character; "*" – for any number of characters)		
fan_size	Size	mm	190, 220, 225, 250, 280, 300, 310, 315, 350, 355, 400, 420, 450, 500, 560, 630, 710, 800, 900, 910, 1000, 1120
mains_operation	Controlled (FU) or uncontrolled operation (mains)		MAINS, FU
motor_technology	Motor technology		AC, EC
nominal_frequency	Line frequency	Hz	50, 60
voltage	Line voltage	V	230, 400, 690, ...
motor_technology	Motor technology		AC, EC, DC
current_phase	Type of current		1, 3
search_tolerance	Search tolerance	%	
motor_safety_margin	Motor safety margin	%	
		%	
air_density	Conveyor density	kg/m ³	
ambient_temperature	Conveyor temperature	°C	
			0, 1, false, true
installation_height_mm	Installation height	mm	
installation_width_mm	Installation width	mm	
installation_length_mm	Installation depth	mm	
protection_class	Protection class IP		IP44, IP54, IP55
erp_class	ErP class		2013, 2015
sfp_class	SFP class		1, 2, 3, 4, 5, 6, 7

The following request parameters can be used with imperial units. Setting the "unit_system": "i" is a prerequisite.

Parameter	Designation	Unit	Values
qv		ft ³ /min	
psf	Static pressure	in.wg.	
pf	Total pressure	in.wg.	
air_density	Conveyor density	lbs/ft ³	
ambient_temperature	Conveyor temperature	°F	
installation_height_in	Installation height	mm	
installation_width_in	Installation width	mm	
installation_length_in	Installation depth	mm	



14.5. Summary Output Parameters

Parameter	Example	Meaning	Unit	Output in function			
				"search"	"select"	"nominal values"	"accessories"
ARTICLE_NO	113662/O01	Article number	-	X	X	X	-
ARTICLE_NO	90144	Accessory article numbers	-	-	-	-	X
CALC_AIR_DENSITY	1,16	Density used by the calculation	kg/m ³	X	X	-	-
CALC_ALTITUDE	213	Altitude used by the calculation	m above sea level	X	X	-	-
CALC_LW5_OKT	63.02,59.30,50.41,49.76,...	Octave band Lw5 (values separated by commas)	dB	-	X	-	-
CALC_LW6_OKT	61.78,58.79,54.00,53.78,...	Octave band Lw6 (values separated by commas)	dB	-	X	-	-
CALC_LWA5_OKT	36.78,41.67,42.01,46.09,...	Octave band Lw(A)5 (values separated by commas)	dB	-	X	-	-
CALC_LWA6_OKT	35.53,41.82,45.43,50.38,...	Octave band Lw(A)6 (values separated by commas)	dB	-	X	-	-
CALC_NOZZLE_PRESSURE	89	Active pressure in nozzle for air	Pa	X	X	-	-
CALC_N_RATED	45	Percentage speed in relation to max. speed	%	X	X	-	-
CALC_P1_MAX	348	Max. motor power consumption electrical	W	-	X	-	-
CALC_PL_MAX	49	Max. impeller power consumption at characteristic by duty point	W	X	X	-	-
CALC_PSYS_MAX	82	Max. system power consumption electrical (incl. motor and controller)	W	-	X	-	-
CALC_TEMP_C	40	Medium temperature for determining the density	°C	-	-	-	-
CAPACITOR_CAPACITANCE	6	Capacity	µF	-	X	X	-
CAPACITOR_VOLTAGE	400	Capacitor voltage	V	-	X	X	-
CHART_VIEWER_URL	http://fansel...	Url of the chart viewer	-	-	X	-	-
CIRCUIT	D	circuit	-	-	X	X	-
COSPHI	0.72	Cos. Phi	-	-	X	X	-
CURRENT_PHASE	1	Type of current	-	-	X	X	-
DENSITY_INFLUENCE	Measuring density	Used density as text	-	X	X	-	-
DENSITY_FM	1.16	Conveyor density	kg/m ³	-	-	-	-
DRAWING_FILE	...\\DummyKlischeeRadial.jpg	Drawing	-	X	X	-	-
EC_TYPE	1	EC type	-	-	X	X	-
EFFICIENCY_STAT	63.5		%	-	X	X	-
EFFICIENCY_TOT	69.1		%	-	X	X	-
ERP_CLASS	2015	ErP class	-	X	X	-	-
ERP_METHOD	A	ErP measuring method	-	X	X	-	-
ERP_N_ACTUAL	70.5	ErP	-	X	X	-	-
ERP_N_STAT	53.5	ErP, static	%	X	X	-	-
ERP_N_TARGET	62	ErP	-	X	X	-	-
ERP_VSD	EC controller integrated	Speed control required/integrated	-	X	X	-	-
GROUP	Mechanical accessory	Accessory group	-	-	-	-	X
GROUP_ID	2	Accessory group ID	-	-	-	-	X
INCREASE_OF_CURRENT	0	Current increase	%	-	X	X	-
INDEX	0	Index search result	-	X	-	-	-
INSTALLATION_HEIGHT_MM	600	Height of the fan	mm	X	X	-	-
INSTALLATION_LENGTH_MM	346	Length of the fan	mm	X	X	-	-
INSTALLATION_WIDTH_MM	600	Width of the fan	mm	X	X	-	-
IS_EC	1	EC fan	-	X	X	-	-
KFACTOR	220	k-factor for determining the nozzle active pressure	-	X	X	-	-
MAX_CURRENT	2.8	Max. current	A	-	X	X	-

Parameter	Example	Meaning	Unit	Output in function			
				"search"	"select"	"nominal values"	"accessories"
MAX_FREQUENCY	79	Max. frequency	Hz	-	X	X	-
MAX_TEMPERATURE_C	60	Max. temperature	°C	-	X	X	-
MAX_VOLTAGE	200	Max. voltage	V	-	X	X	-
MIN_CURRENT	3.9	Min. current	A	-	X	X	-
MIN_PSF	30	Min. static pressure	Pa	-	X	X	-
MIN_TEMPERATURE_C	-25	Min. temperature	°C	-	X	X	-
MIN_VOLTAGE	200	Min. voltage	V	-	X	X	-
MOTOR_DESIGN	IMB 3	Motor design	-	-	X	-	-
MOTOR_POLES	2	Polecount standard motor	-	X	X	-	-
MOTOR_SHAFT	1 / 28x 60	Motor shaft description (number / diameter x length)	Pcs. / mm x mm	-	X	-	-
MOTOR_SIZE	100L	Motor size	-	-	X	-	-
NOMINAL_CURRENT	6.18	Nominal current	A	-	X	X	-
NOMINAL_FREQUENCY	50	Nominal frequency	Hz	-	X	X	-
NOMINAL_IECMOTOR_EFFICIENCY	0.85	(0 - 1)	-	X	X	-	-
NOMINAL_SPEED	1,440	Nominal speed	1/min	-	X	X	-
NOMINAL_VOLTAGE	230	Nominal voltage	V	-	X	X	-
NOZZLE_GUARD	Measured in standard nozzle in installation type A according to ISO 5801	measuring method	-	X	X	-	-
PHASE_DIFFERENCE	0.79	Phase difference	-	-	X	X	-
POWER_INPUT_HP	¾	Power input HP	HP	-	X	X	-
POWER_INPUT_KW	0.75	Power input kW	kW	-	X	X	-
POWER_OUTPUT_HP	3	Power output HP	HP	-	X	X	-
POWER_OUTPUT_KW	3	Power output kW	kW	-	X	X	-
PRODUCT_IMG	C:\...\Vpro-ECblue.jpg	Product image	-	X	X	-	X
PROTECTION_CLASS_IP	IP54	Protection class IP	-	-	X	X	-
PROTECTION_CLASS_THCL	THCL155	Protection class THCL	-	-	X	X	-
RUBBER_IMP_DIAMETER	30	Diameter rubber damper impeller side	mm	-	-	-	-
RUBBER_IMP_HEIGHT	30	Height rubber damper impeller side	mm	-	-	-	-
RUBBER_IMP_NUMBER	2	Number of rubber dampers impeller side	Pcs.	-	-	-	X
RUBBER_IMP_SHORE	55 +-5	Shore hardness rubber damper impeller side	Shore	-	-	-	X
RUBBER_IMP_TYPE	30x30 / 55	Type rubber damper impeller side	-	-	-	-	X
RUBBER_MOT_DIAMETER	30	Diameter rubber damper motor side	mm	-	-	-	-
RUBBER_MOT_HEIGHT	30	Height rubber damper motor side	mm	-	-	-	-
RUBBER_MOT_NUMBER	2	Number of rubber dampers motor side	Pcs.	-	-	-	X
RUBBER_MOT_SHORE	55 +-5	Shore hardness rubber damper motor side	Shore	-	-	-	X
RUBBER_MOT_TYPE	30x30 / 55	Type rubber damper motor side	-	-	-	-	X
SPRING_IMP_DIAMETER	52	Diameter spring damper impeller side	mm	-	-	-	-
SPRING_IMP_HEIGHT	60	Height spring damper impeller side	mm	-	-	-	-
SPRING_IMP_NUMBER	2	Number of spring dampers impeller side	Pcs.	-	-	-	X
SPRING_IMP_RATE	17.3	Spring rate spring damper impeller side	N/mm	-	-	-	X
SPRING_IMP_TYPE	MSN 6	Type spring damper impeller side	-	-	-	-	X
SPRING_MOT_DIAMETER	52	Diameter spring damper motor side	mm	-	-	-	-
SPRING_MOT_HEIGHT	60	Height spring damper motor side	mm	-	-	-	-

Parameter	Example	Meaning	Unit	Output in function			
				"search"	"select"	"nominal values"	"accessories"
SPRING_MOT_NUMBER	2	Number of spring dampers motor side	Pcs.	-	-	-	X
SPRING_MOT_RATE	17.3	Spring rate spring dampers motor side	N/mm	-	-	-	X
SPRING_MOT_TYPE	MSN 6	Type spring damper motor side	-	-	-	-	X
TYPE	GR45V-ZIK.DC.1R	Type key	-	X	X	-	-
TYPE	32F35	Article name	-	-	-	-	X
TYPE_ID	32F35	Article name ID	-	-	-	-	X
VOLTAGE_TOLERANCE	-1	Voltage tolerance	%	-	X	X	-
ZA_BG	450	Size	mm	X	X	-	-
ZA_ETAF	18.34		%	X	X	-	-
ZA_ETAF_L	65.81	T	%	X	X	-	-
ZA_ETAF_L_MAINS_OPERATED	78.44	T	%	X	X	-	-
		Mains operation					
ZA_ETAF_SYS	41.86	T	%	X	X	-	-
ZA_ETAF_SYS_MAINS_OPERATED	54.29	T	%	X	X	-	-
		Mains operation					
ZA_ETAM	85.5		%	X	X	-	-
ZA_ETASF	16.46		%	X	X	-	-
ZA_ETASF_L	59.05		%	X	X	-	-
ZA_ETASF_L_MAINS_OPERATED	70.38		%	X	X	-	-
		Mains operation					
ZA_ETASF_SYS	37.56		%	X	X	-	-
ZA_ETASF_SYS_MAINS_OPERATED	48.72		%	X	X	-	-
		Mains operation					
ZA_FBP	18.92	Frequency in duty point	Hz	X	X	-	-
ZA_I	0.44	Current in duty point	A	X	X	-	-
ZA_LW5	64.99	Acoustic power level Lw5	dB	X	X	-	-
ZA_LW6	64.83	Acoustic power level Lw6	dB	X	X	-	-
ZA_LWA5	52.76	Acoustic power level Lw(A)5	dB	X	X	-	-
ZA_LWA6	56.84	Acoustic power level Lw(A)6	dB	X	X	-	-
ZA_MAINS_SUPPLY	1~ 230V 50Hz	Mains supply	-	X	X	-	-
ZA_N	649.15	Speed in duty point	1/min	X	X	-	-
ZA_N_MAX	1,440	Max. speed	1/min	X	X	-	-
ZA_P1	168.81	Motor electrical power consumption	W	X	X	-	-
ZA_PD	6.15	Dyn. pressure in duty point	Pa	X	X	-	-
ZA_PF	59.86	Total pressure in duty point	Pa	X	X	-	-
ZA_PF_MAINS_OPERATED	300.69	Total pressure in mains operation	Pa	X	X	-	-
ZA_PL	47.04	Impeller power consumption in duty point	W	X	X	-	-
ZA_PSF	53.72	Static pressure in duty point	Pa	X	X	-	-
ZA_PSF_MAINS_OPERATED	269.82	Static pressure in mains operation	Pa	X	X	-	-
ZA_PL	47.04	Impeller power consumption in duty point	W	X	X	-	-
ZA_PSF	53.72	Static pressure in duty point	Pa	X	X	-	-
ZA_PSF_MAINS_OPERATED	269.82	Static pressure in mains operation	Pa	X	X	-	-
ZA_PSYS	82.35	System power consumption electrical	W	X	X	-	-
ZA_QV	2,072,99		m³/h	X	X	-	-
ZA_QV_MAINS_OPERATED	4,646.04		m³/h	X	X	-	-
ZA_PROTECTION_GRILL	NO	Yes/no info for calculatory consideration of the screen protection	-	X	X	-	-
ZA_SFP	146	point	W	X	X	-	-

Parameter	Example	Meaning	Unit	Output in function			
				"search"	"select"	"nominal values"	"accessories"
ZA_SFP_CLASS	1	SFP class in the duty point	-	X	X	-	-
ZA_TC	GR45V-ZIK.DC.1R	Type key	-	-	-	-	-
ZA_U	230	Voltage in the duty point	V	X	X	-	-
ZA_WEIGHT	27.6	Fan weight	kg	X	X	-	-

* The output parameters can differ at zero values

The following request parameters can be used with imperial units. Setting the "unit_system" "i" is a prerequisite.

Parameter	Example	Meaning	Unit	Output in function			
				"search"	"select"	"nominal values"	"accessories"
CALC_AIR_DENSITY	0.007	Density used by the calculation	lbs/ft ³	X	X	-	-
CALC_ALTITUDE	698	Altitude used by the calculation	ft	X	X	-	-
CALC_NOZZLE_PRESSURE	0.357	Active pressure in nozzle for air	in.wg.	X	X	-	-
CALC_P1_MAX	0.466	Max. motor power consumption electrical	hp	-	X	-	-
CALC_PL_MAX	0.065	Max. impeller power consumption at characteristic by duty point	hp	X	X	-	-
CALC_PSYS_MAX	0.1	Max. system power consumption electrical (incl. motor and controller)	hp	-	X	-	-
CALC_TEMP_F	68	Medium temperature for determining the density	°F	-	-	-	-
INSTALLATION_HEIGHT_IN	23,622	Height of the fan	in	X	X	-	-
INSTALLATION_LENGTH_IN	13,622	Length of the fan	in	X	X	-	-
INSTALLATION_WIDTH_IN	23,622	Width of the fan	in	X	X	-	-
MAX_TEMPERATURE_F	122	Max. temperature	°F	-	X	X	-
MIN_PSF	0.36	Min. static pressure	in.wg.	-	X	X	-
MIN_TEMPERATURE_F	-13	Min. temperature	°F	-	X	X	-
RUBBER_MOT_DIAMETER	1,181	Diameter rubber damper motor side	in	-	-	-	-
RUBBER_MOT_HEIGHT	1,181	Height rubber damper motor side	in	-	-	-	-
SPRING_MOT_DIAMETER	1,968	Diameter spring damper motor side	in	-	-	-	-
SPRING_MOT_HEIGHT	2,362	Height spring damper motor side	in	-	-	-	-
ZA_P1	0.226	Motor electrical power consumption	hp	X	X	-	-
ZA_PD	0.02	Dyn. pressure in duty point	in.wg.	X	X	-	-
ZA_PF	0.24	Total pressure in duty point	in.wg.	X	X	-	-
ZA_PF_MAINS_OPERATED	1.21	Total pressure in mains operation	in.wg.	X	X	-	-
ZA_PL	0.063	Impeller power consumption in duty point	hp	X	X	-	-
ZA_PSF	0.22	Static pressure in duty point	in.wg.	X	X	-	-
ZA_PSF_MAINS_OPERATED	1.08	Static pressure in mains operation	in.wg.	X	X	-	-
ZA_PSYS	0.11	System electrical power consumption	hp	X	X	-	-
ZA_QV	2,072.99		m ³ /h	X	X	-	-
ZA_QV_MAINS_OPERATED	2,765.73		ft ³ /min	X	X	-	-
ZA_WEIGHT	7.6	Fan weight	lb	X	X	-	-

15. Document history

15.11.2011 "FANselect-DLL"

- Title sheet added
- Numbering changed
- Examples changed
- Document history added
- Summary of output parameters added

16.11.2011

- Numbering changed
- Document history added

30.11.2011

- Corrections

09.12.2011 "FANselect-DLL"

- Corrections
- Explanation of the "nominal values" function
- Summary of output parameters updated

31.01.2012

- General notes

28.02.2012

- Login
- Definition of the main dimensions
- Type key

09.05.2012 "FANselect-DLL"

- Adaptation chapter 3.1 (definition type IDs)
- Adaptation chapter 3.2 (chart_viewer URL)

30.05.2012

- Formatting
- chapter 5.3, 5.4, 5.5 changed/added

20.08.2012 "FANselect-DLL"

- Adaptation chapter 4 (request parameter product_design)

23.10.2012 "FANselect-DLL"

- Adaptation chapter 3.1 (definition type IDs)

30.10.2012

- Chapter 10.1, 10.2 changed/added

07.01.2013 "FANselect-DLL"

- Chapter 11.1, 10.2 changed/added

07.02.2013 "FANselect-DLL"

- Adaptation chapter 3.1 (note units system "imperial units")
- Adaptation chapter 3.4 (description "motor_data")
- Adaptation chapter 3.5 (description "geo_data")
- Adaptation chapter 4 (parameters in imperial units)
- Adaptation chapter 5 (parameters in imperial units)

11.02.2013

- Chapter 11.1 adapted

04.06.2013

- Combination of the documentations "User's Manual" and "Documentation of the FANselect.dll"



16. ZIEHL-ABEGG global

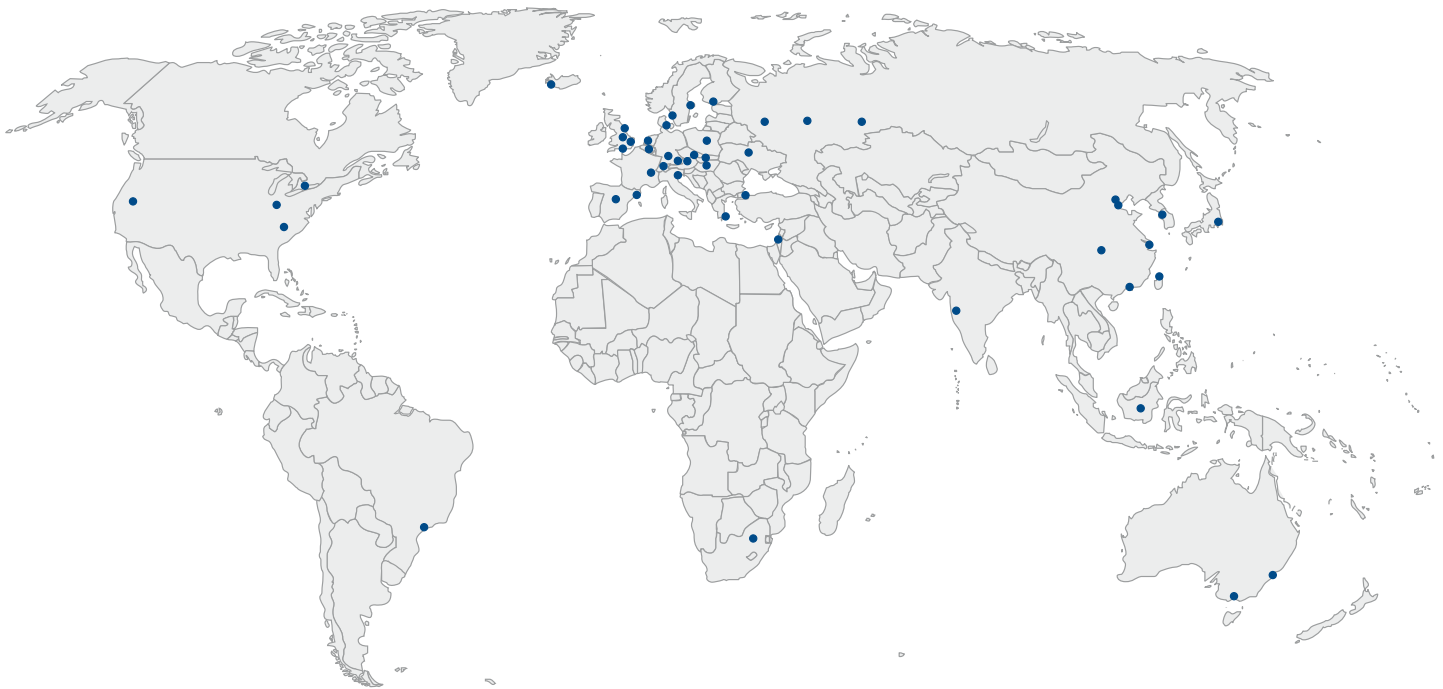

Your contact into the world of ZIEHL-ABEGG

Would you like to learn more about the company ZIEHL-ABEGG, its products and applications?
Your current direct contact partners can always be found at www.ziehl-abegg.com



The Royal League

